

MODELS A, H
ASSEMBLY INSTRUCTIONS

1. Place the engine on the transom of your boat so that it is mounted vertically, in the normal fashion. Open the access plate in the exhaust housing and disconnect the shift rod coupling at the upper cap screw. Remove gearbox cap screws and drop propeller-gearbox assembly.
2. Remove the "O" ring from the top of the driveshaft and the water pump assembly.
3. Next, install the jet pump driveshaft assembly into the spiral pump housing locking it in place with 2 #10-24 fillister head screws and spring lock washers.
4. Install the water pump assembly and "O" ring at the driveshaft spline. Be sure the pump is in good condition and that the rubber impeller fingers are all pointing backwards when turning the driveshaft in a clockwise direction looking down from above. Don't forget impeller drive pin.
5. In removing the propeller unit, it was necessary to disconnect the shift rod at the exhaust housing access hole. This rod would later rattle from vibrations so a spring is provided to urge the loose end of the rod sideways so that it drags in its guide hole. The brass shift rod coupling is removed and the spring is installed with the right angle loop around the groove in the shift rod and the fully bent back loop over the access plate upper screw hole. Leave the access plate gasket in place in the exhaust housing and allow this gasket to wedge between the main body loops of the spring when the flat loop is over the screw hole. This wedging will hold the spring in position long enough to get the plate and screws in place after which the spring loop cannot get out.
6. Tip the engine up toward the horizontal. Next install the jet pump housing and shaft assembly onto the engine, using the 4 $\frac{1}{4}$ -20 screws and lock washers and the 3/8-16 cap screw which held the propeller unit. Be sure, as you guide the unit into position, that the water tube engages the pump. A little grease helps on this rubber coupling. Start all screws into engagement before tightening any one. The 3/8 bolt hole in the engine exhaust housing is die cast, not drilled, and there may be slight binding at this hole. You can relieve the hole with a round file if necessary. Tighten the 4 $\frac{1}{4}$ -20 screws to 125in.-lbs. torque (25 lbs. at the end of a 5 inch wrench for example.)
7. Tip the engine back to a vertical position. Next install the impeller for blade clearance adjustment. Place in position the fiber shaft sleeve, the impeller, shear pin keeper, stack of 6 shim washers, and shaft nut. Bring the nut up snug. Install the water intake, locking in place with 2 screws only. Look inside. Clearance between the blade edge and casing should be 1/64 to 1/32 inch. (A shim washer for example is 1/32 thick.) If clearance is excessive, place one shim washer above the impeller and repeat.

MODELS A, H

8. Now remove the intake casing and reassemble as follows:

If shims are required, place the proper number above the impeller, place the plastic impeller sleeve on the shaft. Put on the impeller, the shear pin, the shear pin keeper, the remaining shims from the stack of 6, and the nut. (See paragraph 9). Turn the nut up snug and then bump the wrench further until the cotter pin hole lines up. Put in the cotter pin and fold the ends around. If erosion or wear in abrasive conditions open the blade tip clearance up excessively, there will be a loss of pressure and performance. At this point one or two shims, as required, would be removed from the lower stack and placed on the shaft above the impeller which moves it down into the casing taper, thus reducing the clearance.

9. Model A jets now use a drive key instead of a shear pin with shear pin keeper, and 9 shims instead of 6.

10. Place the intake casing in position with the $\frac{1}{4}$ inch lip forward and tighten the 6 screws.

11. To attach the gate shift linkage, remove the shift lever which is held in place with a screw in the split clamp and a $\frac{1}{4}$ -20 cap screw and star lock washer. Be careful not to lose the star lock washer. Place the sheet metal shift arm in position and replace the shift lever. The star lock washer must be placed beneath the sheet metal shift arm or the aluminum shift lever will be cracked when the cap screw is tightened. Tighten the cap screw initially in the center of the slot in the shift lever.

12. Next, attach the shift rod. The spring clip is used at the upper end and the flat washer with cotter pins used at both ends. Adjustment should be made on the length of this rod so that with the shift lever in the forward position, the gate is forced solidly against the rubber pad beneath the pump housing so that there is no rattle in the system. Further refinements in adjustment should be made at the cap screw in the slotted hole on the shift lever such that in "forward" the triangular shift arm comes on center, in line with the shift rod. This provides an "on center" locking toggle to prevent the gate from being pushed into reverse by water motion. (See Sheet 4.) Next lock all screws. Do not be concerned if, in reverse position, the gate is not entirely closed. The pivot positions on the gate are designed so that water pressure holds the gate in reverse. In fact, you will not be able to shift to forward from reverse if the engine is running above a fast idle due to this water pressure. You can, however, shift to reverse at any forward speed and this can be dangerous since the engine will kick up just as though you had hit a log with a propeller unit. Use caution here or tie your engine down if you want to experiment with getting wet.

13. Lubricate the shaft bearing as explained in separate sheet,
MAINTENANCE AND LUBRICATION.

MODELS A, H, Q

14. When converting to jet drive, your motor will have to be raised to the height shown below, using a straight edge under the boat. Test run the boat and then raise or lower the motor $\frac{1}{4}$ " at a time to obtain the best results, using wood shim under the motor clamps. If you raise it too much it will suck air and cavitate, either on start up or when banking on turns. When cavitating, the engine overspeeds in spurts and shakes considerably in the engine mount. This is not a normal condition and should be avoided by proper adjustment of engine height on each individual boat. If you lower it too much you will have excessive drag, therefore mount the engine as high as possible without allowing cavitation. Good boating and have fun!

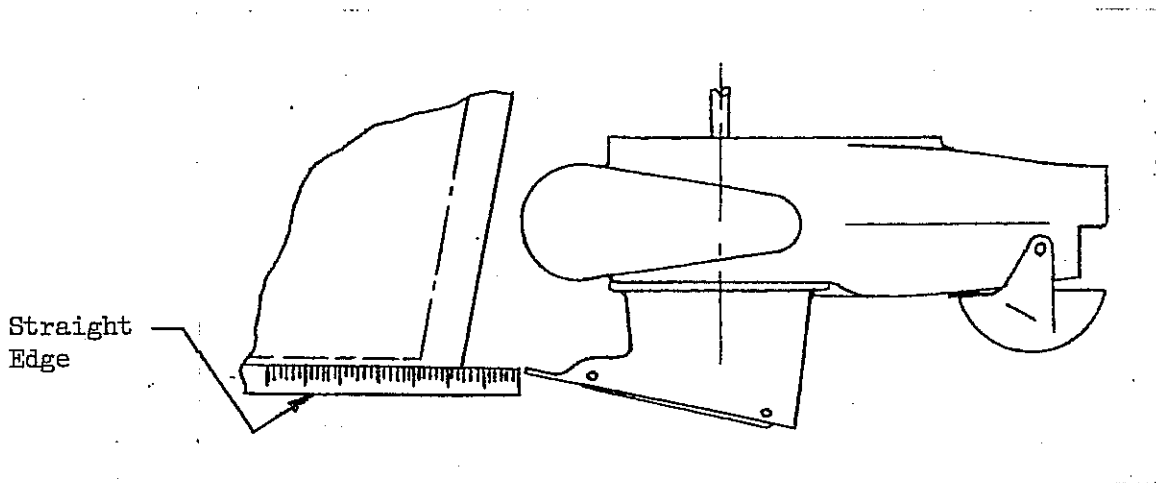

CAUTION!

When starting the engine for the first time, watch to see that cooling water comes out of the cooling water outlet at the rear of the engine just below the powerhead. This is to check your assembly of the cooling water pump and its connections.

MAINTENANCE AND LUBRICATION

See separate sheet.

OUTBOARD JETS
2035 Edison Avenue
San Leandro, California 94577

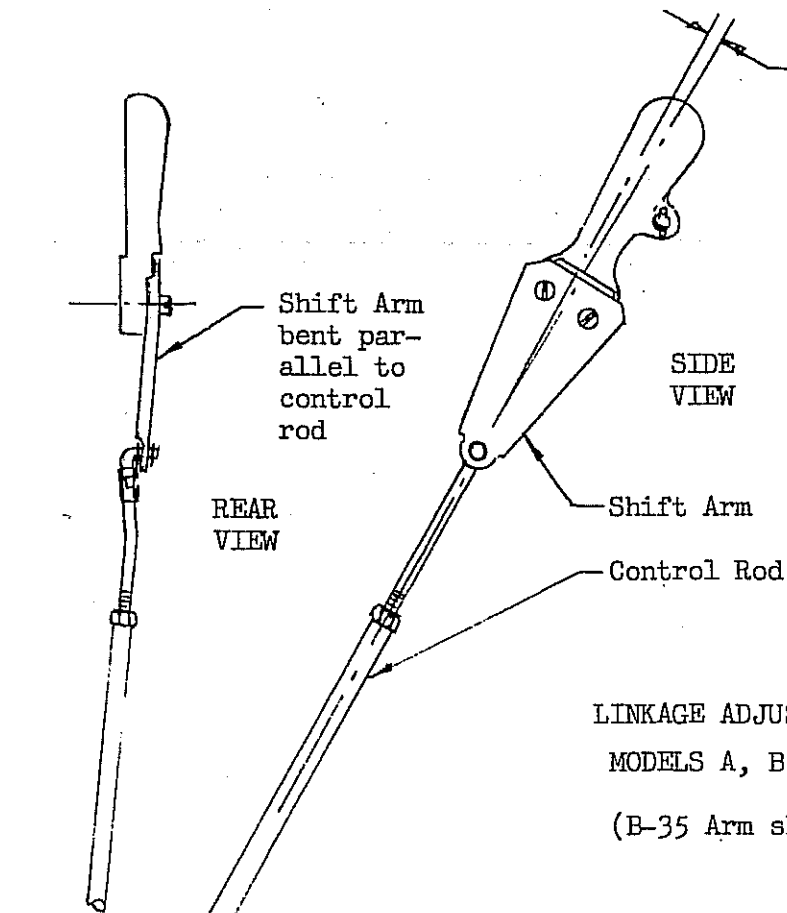

In the forward position the control rod centerline should be slightly to the rear of the shift arm centerline. This provides an "over center" toggle locking effect which prevents the gate from being forced into reverse. Slot the screw holes in the shift arm if necessary to allow reaching this position. Adjust the length of the control rod so that the gate is forced solidly against the rubber pad in forward position.

LINKAGE ADJUSTMENT
 MODELS A, B, H, Q
 (B-35 Arm shown)

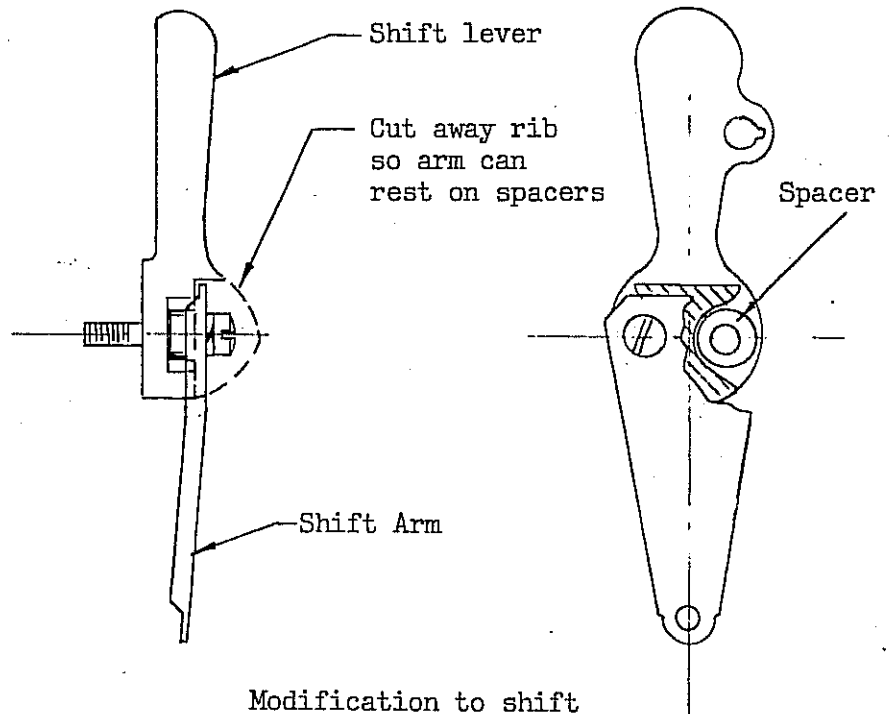
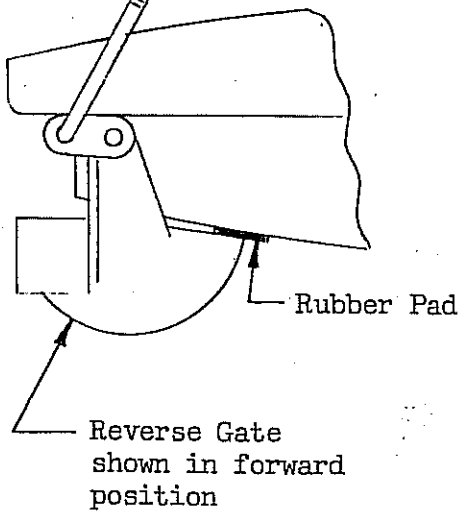

Modification to shift lever to receive B-35 Shift Arm and Spacers. Evinrude shift lever Part. No. 278282 can be used without modification.

MAINTENANCE AND LUBRICATION OUTBOARD JET DRIVE

BEARING LUBRICATION

A grease gun and tube of grease is supplied with your jet drive. We recommend greasing the bearing every 10 hours. Make greasing a part of your cleanup after the days use. Pump in just enough grease to fill the lube hose. Then reconnect the lube hose coupling to the zerk grease fitting.

Every 30-40 hours, pump in extra grease so as to purge any moisture. The texture of the grease coming out gives an indication of conditions inside the bearing housing. A gradual increase in moisture content indicates seal wear. If the grease begins to turn dark, dirty gray, the bearing and seals should be inspected and replaced if necessary. Some discoloration of the grease is normal during the break in period on new sets of seals.

We have selected a water resistant grease of the proper consistency for this application. If you use a substitute grease, be sure it is water resistant and of the same consistency.

IMPELLER

Your jet drive is equipped with a key to protect the unit in the event of a rock jam. This can be reached by removing the water intake, and then the driveshaft nut, similar to a propeller drive. After replacing the key, pull the shaft nut up tight to remove any play between the impeller and shaft. Note the position of the impeller shim washers, and replace them in the same order.

REVERSE GATE MECHANISM

Occasionally check adjustment of the gate shifting linkage. In "forward" the gate should be firmly locked in position. Pull on the gate by hand to verify this. This will prevent wave action from accidentally shifting the gate into reverse as the boat is violently maneuvered

GENERAL

Check all mounting bolts, intake screws, linkage connections, etc., occasionally to be sure they are tight.

SALT WATER USE

Aluminum and stainless steel have been used in the construction of your jet drive. These materials have either been treated or are inherently resistant to corrosion. It is recommended, however, that when not in use the motor be tipped up so that the jet unit is out of the water. When used in salt water more than in fresh water, remove mounting hardware, grease, and reassemble once a year. Failure to do this may result in hardware that is difficult if not impossible to remove at a later date.

GUARANTEE

Due to inflexible government regulation, we do not have a written warranty. We have, however, a good reputation for fairness with our customers which we intend to maintain. If you think you have a warranty situation, regarding material, workmanship, call us before making repairs.

Specialty Manufacturing Company
Outboard Jets
2035 Edison Avenue
San Leandro, CA 94577

MODEL H9 EVINRUDE/JOHNSON

REF	QTY	PART NO	DESCRIPTION	REF	QTY	PART NO	DESCRIPTION
1	1	28	SHIFT SPRING A H O				
2	4	640	WASHER SPRING LOCK 5/16 1983 & LATER				
3	4	595	BOLT HEX HD 5/16-18 X 2 1983 & LATER				
4	4	638	WASHER SPRING LOCK 1/4 1982 & PRIOR				
5	4	578	BOLT HEX HD 1/4-20 X 1 3/4 1982 & PRIOR				
6	4	365.2 8900	ADAPTER SLEEVE H9 1982 & PRIOR VOLUTE WITH GATE H9				
7	1	89	VOLUTE WITH EXHAUST TUBE H9				
8	1	221	EXHAUST TUBE SMALL 1 1/2				
9	1	847	CLIP EXHAUST TUBE 3/4				
10	2	621	NYLOC 10-32				
11	1	975	LUBE HOSE ASSY				
12	1	539	ZIRC FITTING 1/4-28				
13	1	550	GREASE GUN				
14	1	552	GREASE 10 OZ TUBE NO. 630-AA				
15	1	825	GATE PAINTED HV 3/8				
16	2	535	NYLINER 3/8 ID X 11/16				
17	2	821	PIN GATE PIVOT 3/8 SMALL				
18	2	574	BOLT HEX HD 1/4-20 X 3/4 PATCH				
19	1	1177	SPRING GATE PIVOT 3/8				
20	1	533	NYLINER 1/4 ID X 1/4				
21	1	82	GATE CUSHION				
22	1	409	SHAFT ASSY COMPLETE, H9, 14T				
23	1	409.3	SHAFT ONLY, H9, 14T 23 7/8 LG				
24	1	41	SHAFT BEARING THRUST RING				
25	1	477	COLLAR BACKFIT 7205				
26	1	832	THRUST WASHER				
27	1	504	BEARING 7205B-UA				
28	1	511	TRUARC 5100-98				
29	1	833	SPACER				
30	1	512	TRUARC N5002-212ZD				
31	1	433	UPPER SEAL CARRIER W/SEALS & O RINGS				
32	4	517	SPIROLOX RR-150S				
33	2	506	SEAL INNER				
34	2	507	SEAL OUTER 6324-S				
35	2	526	O RING 568-135 3/32X1 15/16X2 1/8				
36	1	413	BEARING CARRIER W/SEALS & O RINGS H9				
37	3	521	O RING 568-011 1/16X5/16X7/16				
38	2	637	WASHER SPRING LOCK #10				
39	2	561	FIL HD SLOTTED 10-24 X 5/8				
40	1	414	INPELLER 6-79 W/36 SLEEVE				
41	1	36	SHAFT SLEEVE PLASTIC MEDIUM				
42	1	782	INPELLER TEE KEY				
43	9	21	SHIM WASHER MEDIUM				
44	1	805	NUT KEEPER MED/PKG 2 PER BAG				
45	1	22.1	SHAFT NUT 5/8-18 BRASS				
46	1	224.2	INTAKE ASSY 6 WITH GRILL & LINER				
47	1	855	LINER 6 W/HARDWARE				
48	2	638	WASHER SPRING LOCK 1/4				
49	2	572	BOLT HEX HD 1/4-20 X 5/8				
50	1	853	INTAKE PAINTED ONLY				
51	2	216	GRILL ROD SMALL				
52	8	215	GRILL BAR SMALL				
53	6	573	BOLT HEX HD 1/4-20 X 3/4				

22. JUL. 97

SIZE

TORQUE

1/4-20 (M6) 8-9 FT-LBS

5/16-18 (M8) 12

3/8-16 (M10) 22

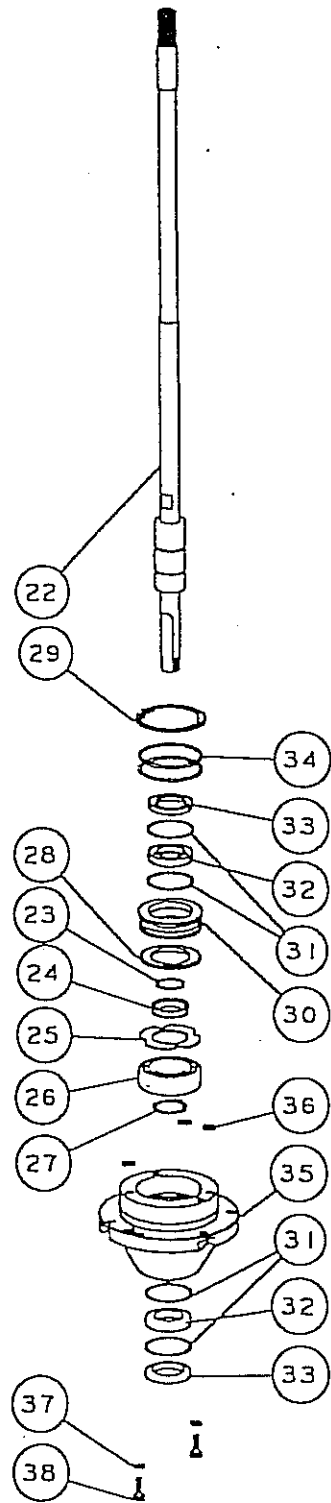
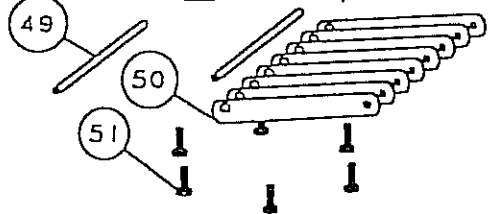
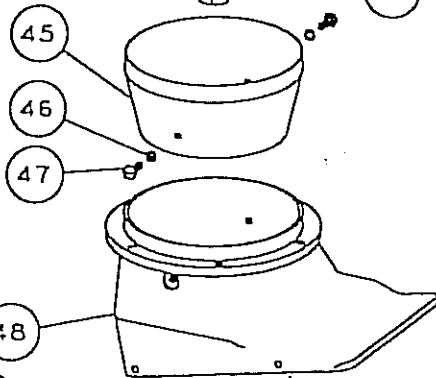
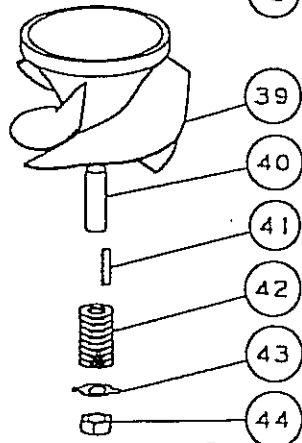
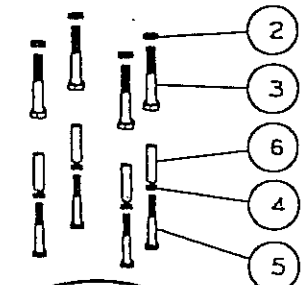
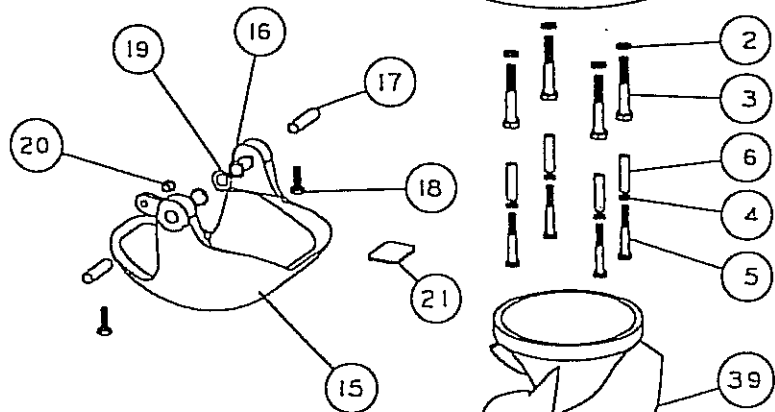
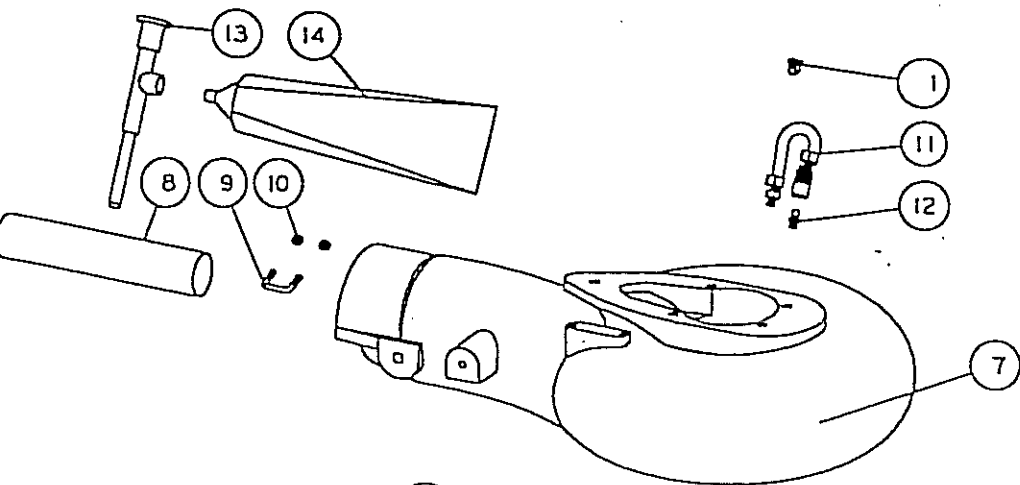

MODEL H EVINRUDE/JOHNSON

REF	QTY	PART NO	DESCRIPTION	REF	QTY	PART NO	DESCRIPTION
1	1	28	SHIFT SPRING A H O				
2	4	638	WASHER SPRING LOCK 1/4				
3	4	578	BOLT HEX HD 1/4-20 X 1 3/4				
		22600	VOLUTE WITH GATE H				
4	1	226	VOLUTE WITH EXHAUST TUBE H				
5	1	221	EXHAUST TUBE SMALL 1 1/2				
6	1	847	CLIP EXHAUST TUBE 3/4				
7	2	621	NYLOC 10-32				
8	1	975	LUBE HOSE ASSY				
9	1	539	ZIRC FITTING 1/4-28				
10	1	550	GREASE GUN				
11	1	552	GREASE 10 OZ TUBE NO.630-AA				
12	1	825	GATE PAINTED HV 3/8				
13	2	535	NYLINER 3/8 ID X 11/16				
14	2	821	PIN GATE PIVOT 3/8 SMALL				
15	2	574	BOLT HEX HD 1/4-20 X 3/4 PATCH				
16	1	1177	SPRING GATE PIVOT 3/8				
17	1	533	NYLINER 1/4 ID X 1/4				
18	1	82	GATE CUSHION				
		225	SHAFT-ASSY COMPLETE, H, 4T				
19	1	214	SHAFT ONLY, H, 4T 23 15/16 LG				
20	1	41	SHAFT BEARING THRUST RING				
21	1	477	COLLAR BACKFIT 7205				
22	1	832	THRUST WASHER				
23	1	504	BEARING 7205B-UA				
24	1	511	TRUARC 5100-98				
25	1	833	SPACER				
26	1	512	TRUARC N5002-2122D				
27	1	433	UPPER SEAL CARRIER W/SEALS & O RINGS				
28	4	517	SPIROLOX RR-150S				
29	2	506	SEAL INNER				
30	2	507	SEAL OUTER 6324-S				
31	2	526	O RING 568-135 3/32X1 15/16X2 1/8				
32	1	208	BEARING CARRIER W/SEALS & O RINGS H				
33	3	521	O RING 568-011 1/16X5/16X7/16				
34	2	637	WASHER SPRING LOCK #10				
35	2	561	FIL HD SLOTTED 10-24 X 5/8				
36	1	206	IMPELLER 5 3/4 W/220 SLEEVE 18 HP				
36	1	207	IMPELLER 6 W/220 SLEEVE 25 HP				
37	1	220	SHAFT SLEEVE PLASTIC SMALL				
38	1	223	SHEAR PIN 3/16 SMALL				
39	1	217	SHEAR PIN KEEPER				
40	6	218	SHIM WASHER SMALL				
41	1	646	COTTER PIN 3/32 X 1 1/4				
42	1	222	SHAFT NUT DRILLED 1/2-20				
		224.1	INTAKE ASSY 5 3/4 WITH GRILL & LINER 18 HP				
43	1	287	LINER 5 3/4 W/HARDWARE				
		224.2	INTAKE ASSY 6 WITH GRILL & LINER 25 HP				
43	1	855	LINER 6 W/HARDWARE				
44	2	638	WASHER SPRING LOCK 1/4				
45	2	572	BOLT HEX HD 1/4-20 X 5/8				
46	1	204	INTAKE PAINTED ONLY 5 3/4				
46	1	853	INTAKE PAINTED ONLY 6				
47	2	216	GRILL ROD SMALL				
48	8	215	GRILL BAR SMALL				
49	6	573	BOLT HEX HD 1/4-20 X 3/4				

29. JUL. 97

SIZE TORQUE

1/4-20 (M6) 8-9 FT-LBS

5/16-18 (M8) 12

3/8-16 (M10) 22

SHIFT ROD ASSEMBLY
 EVINRUDE/JOHNSON MODELS H, H79
 227

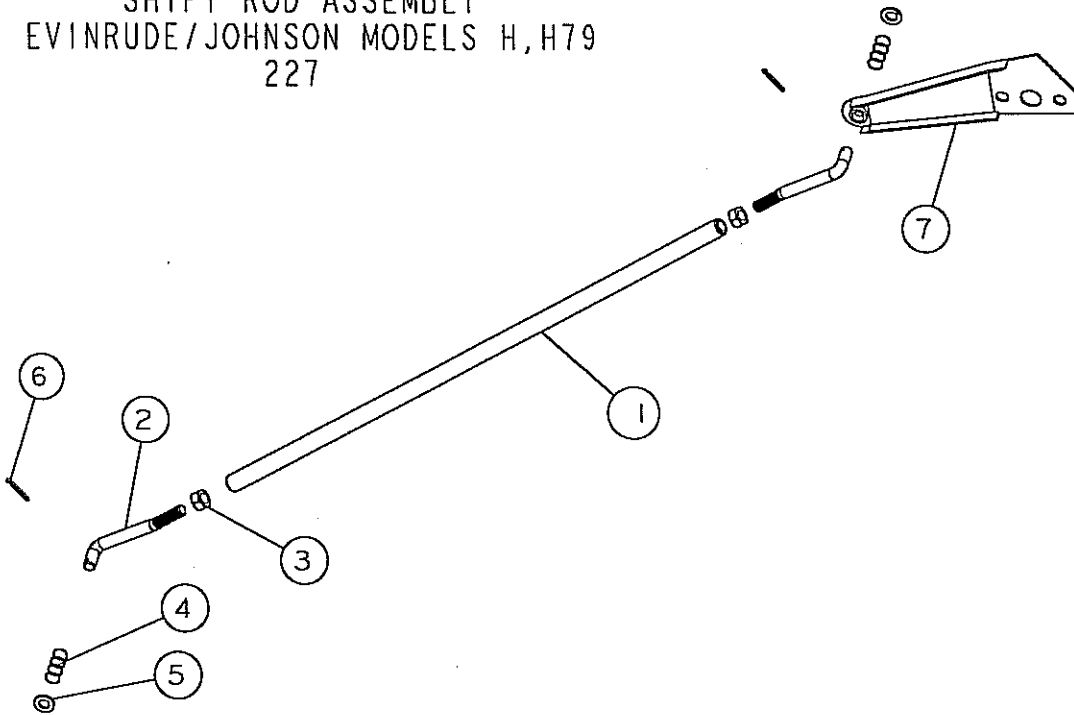

REF	QTY	PART NO	DESCRIPTION
1	1	219	SHIFT ROD H 14 5/16
2	2	24	ROD END FORMED
3	2	622	NUT HEX 1/4-28
4	2	1164	SPRING-ROD END
5	2	635	1/4 WASHER AN960C416
6	2	645	COTTER PIN 1/16 X 1/2
7	1	211	SHIFT LEVER HQ