

MODEL "AE" SERIES

for Tohatsu/Nissan Motors 25-30 HP, 1988 to present

1. Place the engine on the transom of your boat so that it is mounted vertically, in the normal fashion. Disconnect the gearshift rod inside the motor compartment. Remove the 5 bolts holding the gearbox to the exhaust housing and remove the gearbox assembly.
2. Remove the water pump assembly from the propeller drive, including the lower stainless steel plate, upper gasket, pump housing and impeller drive key.
3. Next, install the jet pump driveshaft assembly into the spiral pump housing locking it in place with two #10-24 fill head screws and spring lockwashers.
4. Install the water pump assembly on top of the 1-3/8 inch thick aluminum adapter. It may be necessary to open up the holes in the stainless steel pump plate to clear the mounting bolts. Use gaskets over and under the pump plate and be sure to install the impeller drive key. Lock in place with four 1/4-20 x 2-3/4 bolts and flat washers. Grease the threads.
5. The large adapter plate is attached to the exhaust housing to hold the jet drive. Use five M8 x 1.25 x 30MM bolts and five lockwashers. Grease the threads.
6. Next, attach the jet drive to the motor. Four 5/16-18 x 2 bolts and lockwashers from below and one 3/8-16 x 1-1/4 bolt from above rear, are used.

Grease the bolt threads, driveshaft spline generously, and rubber water tube inlet and guide the jet into place. Tighten the 5 bolts.

7. Next, install the impeller. Grease the shaft threads, key and impeller bore. Place the plastic sleeve inside the impeller, hold the key in the nose of the impeller with your forefinger and slide onto the driveshaft. Install the 8 shim washers and nut retainer on the shaft, up against the impeller, and bring the nut up snug by hand. Be careful that the retainer does not fall into the thread groove and jam the nut.

Place the water intake in position and secure with 2 bolts. Observe the clearance between the impeller blade edge and the intake liner. Then remove the intake.

When, after use in sand and gravel, the blade clearance becomes more than about 1/32" between the impeller edge and the water intake liner, one or more of the stainless shim washers can be transferred from the bottom stack to the top of the impeller, which moves the impeller down into the tapered casing to reduce the clearance.

Shims should not be used above the impeller on new installations, where no wear has occurred, unless the blade clearance exceeds 1/32". Insufficient blade clearance will do more harm than good from any performance gains it might provide.

When the impeller clearance is satisfactory, bump the nut up snug with a wrench. If the ears of the retainer do not line up with the flats on the nut, spin the nut off, turn the retainer over and tighten the nut again. In one of these two positions you will have alignment and can fold the ears up against the nut to retain it. The flat in the retainer is angled to the ears to allow this.

MODEL "AE"

8. Place the intake casing in position with the lower end at the rear and tighten the six 1/4-20 x 3/4 bolts. No lockwashers are used. Grease the threads.
9. If you use remote controls or use a steering tiller handle, a pressed steel shift lever must be attached to the gearshift handle to operate the reverse gate. Clamp the lever to the handle, as shown on page 3 with a small "C" clamp. Center the "C" clamp between the two holes in the lever which will cause it to lie properly against the handle. Using a 3/16 inch drill, drill through the lever from both sides, then run the drill all the way through each screw hole to size the holes. Do not try to do the drilling all from one side or you may not come out in the right places on the far side. Attach the lever using two #10-32 x 1-1/2 fil head screws and lock nuts.
10. Next, attach the shift rod. A spring, flat washer and cotter pin is used at both ends. Adjustment should be made on the length of this rod so that with the shift lever in the forward position, the gate is forced solidly against the rubber pad beneath the pump housing so that there is no rattle in the system. The pivot positions on the gate are designed so that water pressure holds the gate in reverse. In fact, you will not be able to shift to forward from reverse if the engine is running above a fast idle due to this water pressure. You can, however, shift to reverse at any forward speed and this can be dangerous since the engine will kick up just as though you had hit a log with a propeller unit. Use caution here or tie your engine down if you want to experiment with getting wet. The neutral position on the throttle control does not give a dead neutral on the reverse gate. When cold starting the motor, leave the lines holding the boat to the dock secure, or beach the bow of the boat so as to not be thrown off balance when the engine starts.
11. When converting to jet drive, your motor will have to be raised to height shown in diagram on page 3, using a straight edge under the boat. Test run the boat and then raise or lower the motor 1/4 inch at a time to obtain the best results. If you raise it too much it will suck air and cavitate, either on start up or when banking on turns. When cavitating, the engine overspeeds in spurts and shakes considerably in the engine mount. This is not a normal condition and should be avoided by proper adjustment of engine height on each individual boat. If you lower it too much you will have excessive drag, therefore mount the engine as high as possible without allowing cavitation.

MODEL "AE"

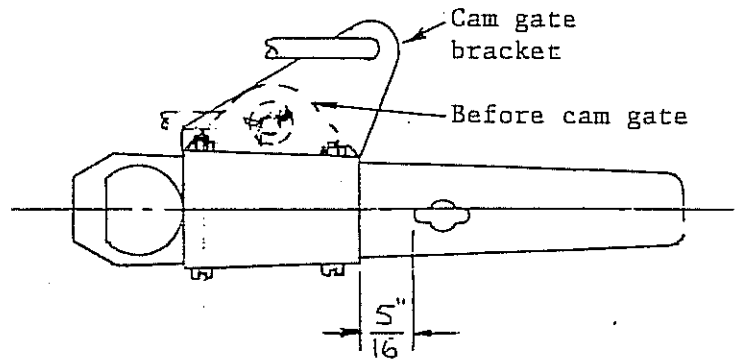
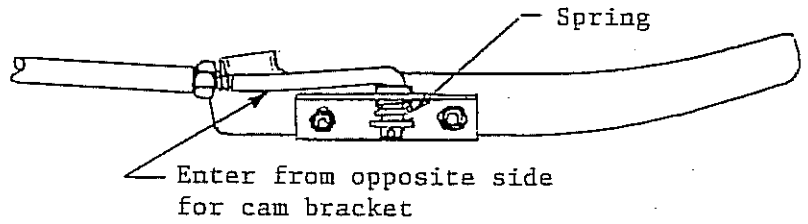
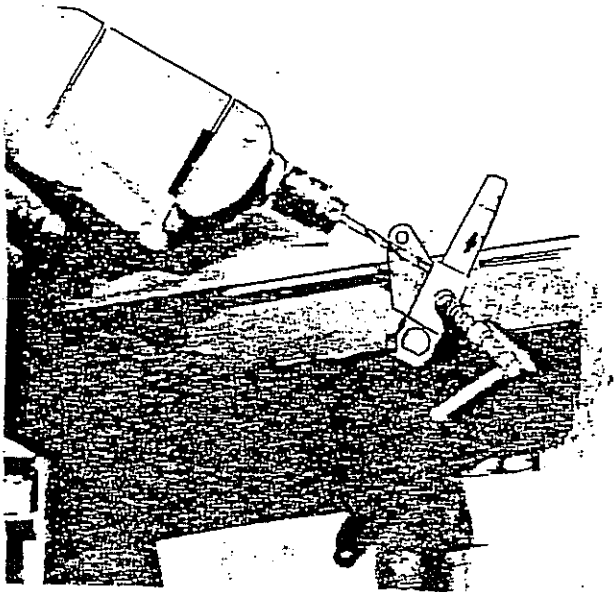

PROPER ENGINE HEIGHT

Straight Edge

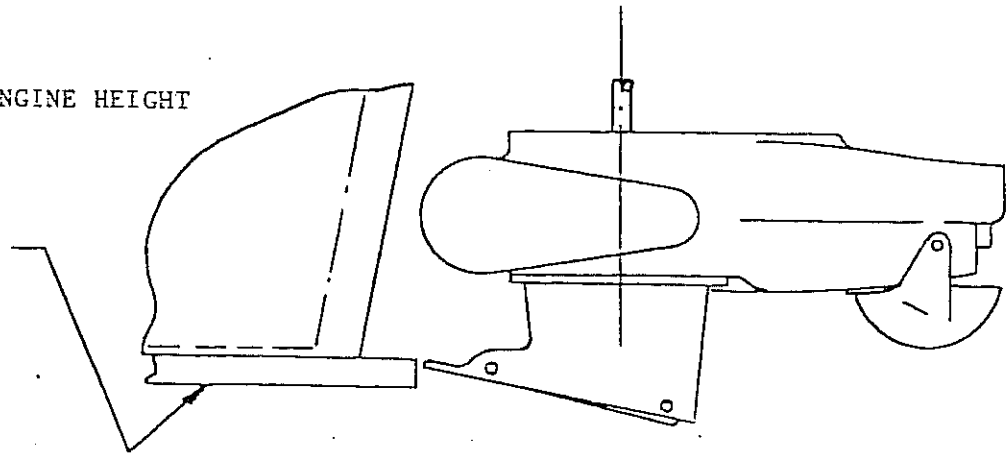

CAUTION When starting the engine for the first time, watch to see that cooling water comes out the small hole at the rear side of the engine just below the powerhead. This is to check your assembly of the cooling water pump and its connections.

MAINTENANCE AND LUBRICATION

See separate sheet.

GOOD BOATING AND HAVE FUN!

Specialty Manufacturing Company
 Outboard Jets
 2035 Edison Avenue
 San Leandro, CA 94577

MAINTENANCE AND LUBRICATION OUTBOARD JET DRIVE

BEARING LUBRICATION

A grease gun and tube of grease is supplied with your jet drive. We recommend greasing the bearing every 10 hours. Make greasing a part of your cleanup after the days use. Pump in just enough grease to fill the lube hose. Then reconnect the lube hose coupling to the zerk grease fitting.

Every 30-40 hours, pump in extra grease so as to purge any moisture. The texture of the grease coming out gives an indication of conditions inside the bearing housing. A gradual increase in moisture content indicates seal wear. If the grease begins to turn dark, dirty gray, the bearing and seals should be inspected and replaced if necessary. Some discoloration of the grease is normal during the break in period on new sets of seals.

We have selected a water resistant grease of the proper consistency for this application. If you use a substitute grease, be sure it is water resistant and of the same consistency.

IMPELLER

Your jet drive is equipped with a key to protect the unit in the event of a rock jam. This can be reached by removing the water intake, and then the driveshaft nut, similar to a propeller drive. After replacing the key, pull the shaft nut up tight to remove any play between the impeller and shaft. Note the position of the impeller shim washers, and replace them in the same order.

REVERSE GATE MECHANISM

Occasionally check adjustment of the gate shifting linkage. In "forward" the gate should be firmly locked in position. Pull on the gate by hand to verify this. This will prevent wave action from accidentally shifting the gate into reverse as the boat is violently maneuvered

GENERAL

Check all mounting bolts, intake screws, linkage connections, etc., occasionally to be sure they are tight.

SALT WATER USE

Aluminum and stainless steel have been used in the construction of your jet drive. These materials have either been treated or are inherently resistant to corrosion. It is recommended, however, that when not in use the motor be tipped up so that the jet unit is out of the water. When used in salt water more than in fresh water, remove mounting hardware, grease, and reassemble once a year. Failure to do this may result in hardware that is difficult if not impossible to remove at a later date.

GUARANTEE

Due to inflexible government regulation, we do not have a written warranty. We have, however, a good reputation for fairness with our customers which we intend to maintain. If you think you have a warranty situation, regarding material, workmanship, call us before making repairs.

Specialty Manufacturing Company
Outboard Jets
2035 Edison Avenue
San Leandro, CA 94577

MODEL AE CAM GATE

Shift Rod Assembly Instructions

Short Shaft #1385

1. Install the pressed steel shift bracket on the shift handle as explained on page 2 & 3 of the installation instructions.
2. Place the reverse gate in forward with the cam roller at the end of the slot in the cam.
3. Place the shift handle in forward, solidly locked in the forward detent.
4. Adjust the length of the shift rod to reach this position. Note that the rod ends enter the holes from the outside. Install the rod temporarily and shift to reverse and then back to forward. The roller should be at the end of the slot in the cam such that the gate cannot be forcibly rotated toward reverse. Pull on the gate by hand to verify this. If this forward lock position is not met, readjust the rod length giving less importance to neutral. Lock the rod end nuts and cotter pins.
5. Return to paragraph 11, page 2.

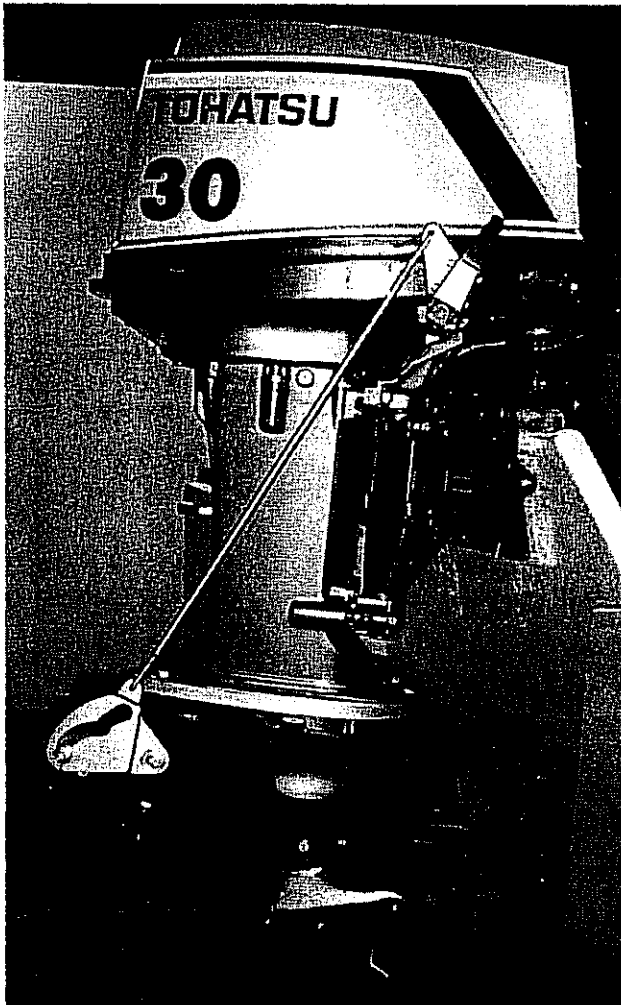

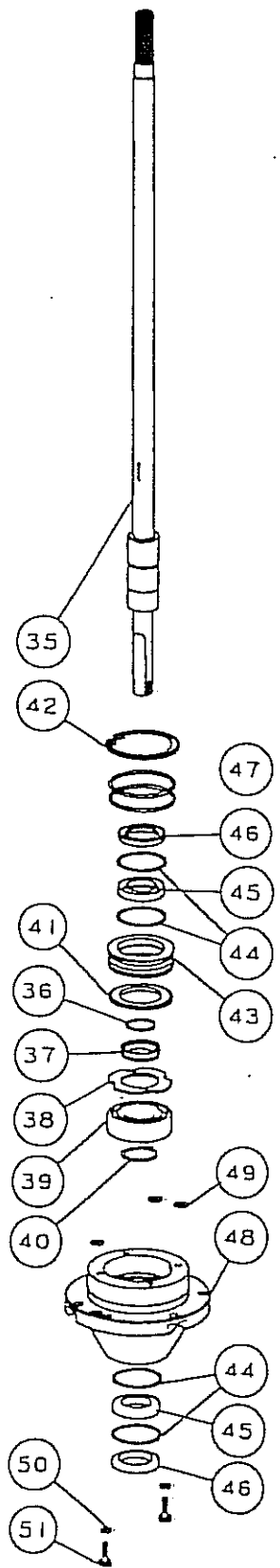
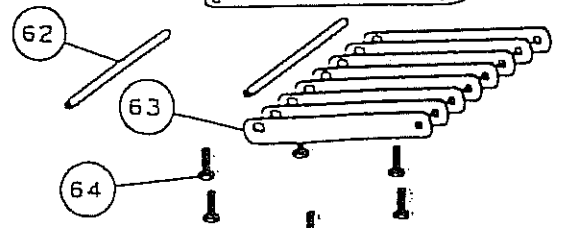
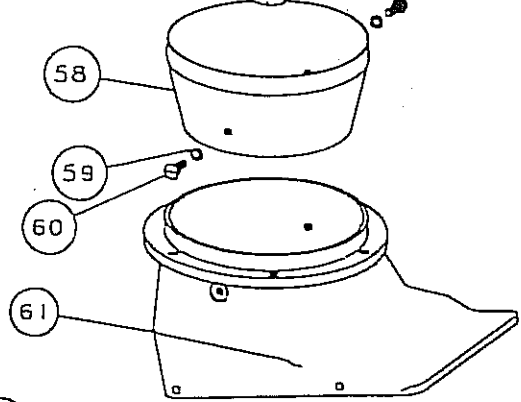
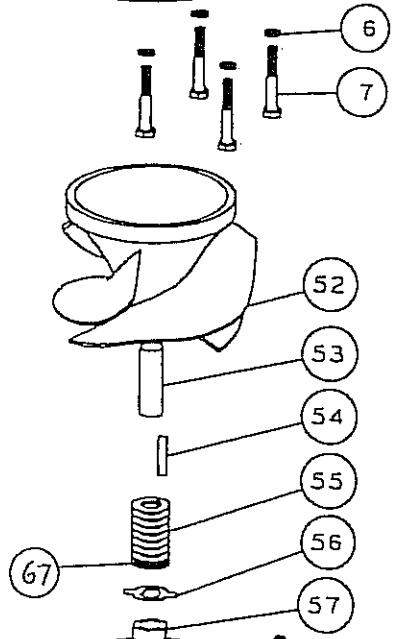
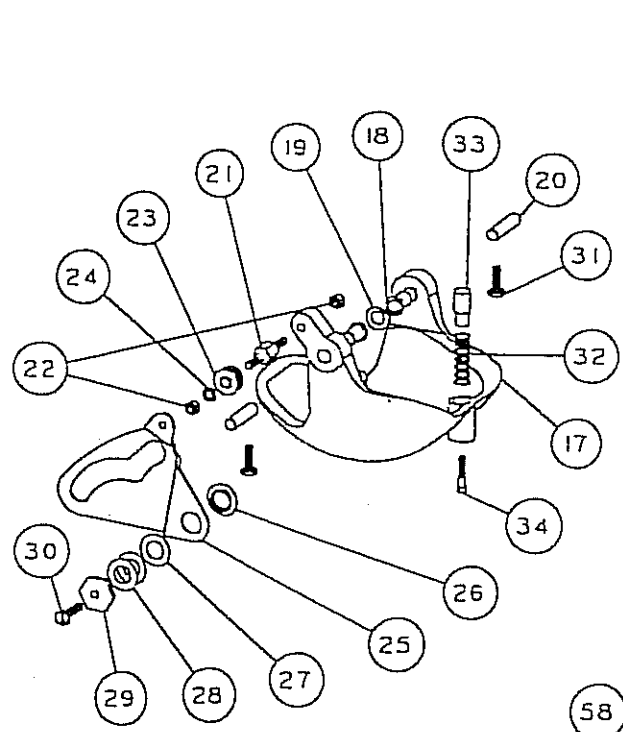
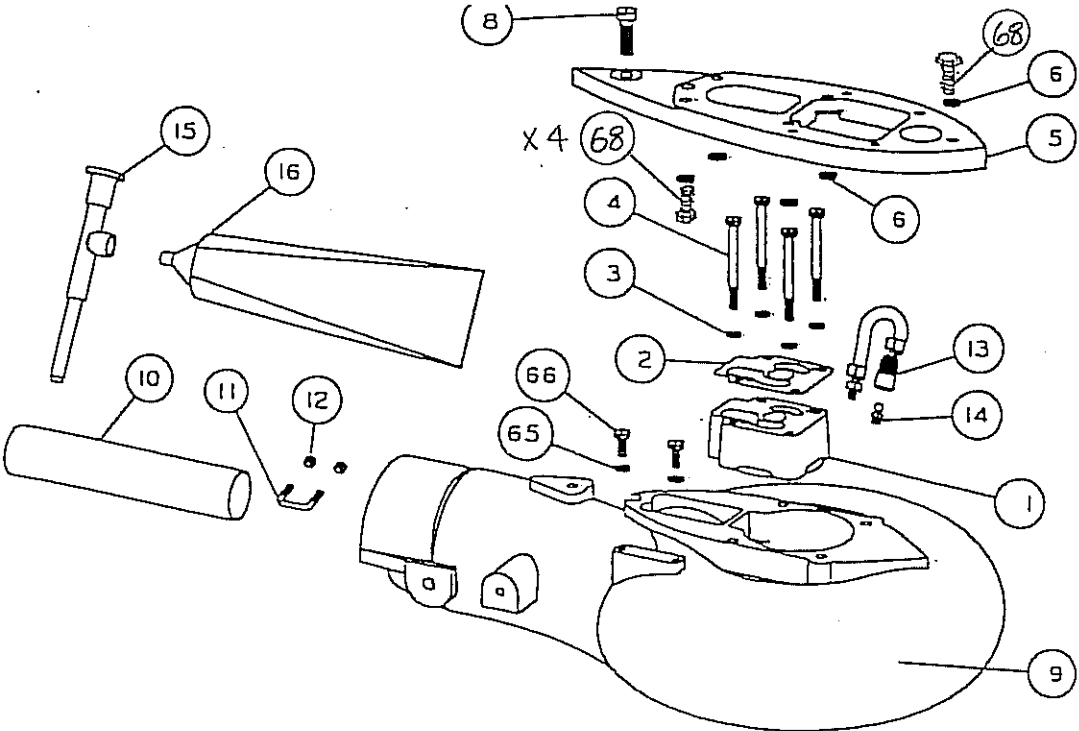

MODEL AE

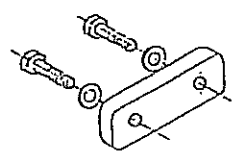

ANODE KIT 1693

MODEL AE TOHATSU / NISSAN

2 STROKE 2 CYL 25-30HP

REF	QTY	PART NO.	DESCRIPTION	REF	QTY	PART NO.	DESCRIPTION
1	1	1138	PUMP ADAPTER AE	52	1	414	IMPELLER 6-79 W/36.1 SLEEVE 25-30HP
2	1	1139	GASKET WATER PUMP AE	53	1	36.1	SHAFT SLEEVE PLASTIC MEDIUM
3	7	635	1/4 WASHER AN960C416	54	1	1705	IMPELLER TEE KEY - 1/2 ROUND
4	4	581	BOLT HEX HD 1/4-20 X 2 3/4	1	1	782	IMPELLER TEE KEY - SQUARE
5	1	1141	ADAPTER PLATE AE	55	8	21	SHIM WASHER MEDIUM
6	9	640	WASHER SPRING LOCK 5/16	56	1	805	NUTKEEPER MED/PKG 2 PER BAG
7	4	595	BOLT HEX HD 5/16-18 X 2	57	1	22.1	SHAFT NUT 5/8-18 BRASS
8	1	606	BOLT HEX HD 3/8-16 X 1 1/4	1	1	224.2	INTAKE ASSY 6 WITH GRILL & LINER
		11470	VOLUTE WITH GATE AE	58	1	855	LINER 6 W/HARDWARE
9	1	1148	VOLUTE WITH EXHAUST TUBE AE	59	2	638	WASHER SPRING LOCK 1/4
10	1	221	EXHAUST TUBE SMALL 1 1/2	60	2	572	BOLT HEX HD 1/4-20 X 5/8
11	1	847	CLIP EXHAUST TUBE 3/4	61	1	853	INTAKE PAINTED ONLY
12	2	621	NYLOC 10-32	62	2	216	GRILL ROD SMALL
13	1	975	LUBE HOSE ASSY	63	8	215	GRILL BAR SMALL
14	1	539	ZIRC FITTING 1/4-28	64	6	573	BOLT HEX HD 1/4-20 X 3/4
15	1	550	GREASE GUN	65	2	635	1/4 WASHER AN960C416
16	1	552	GREASE 10 OZ TUBE 630-AA	66	2	572	BOLT HEX HD 1/4-20 X 5/8
17	1	1355	REVERSE GATE SMALL	67	1	1718	TORSIONAL DAMPER 5/8
18	2	535	NYLINER 3/8 ID X 11/16	68	5	591	BOLT HEX HD M8-1.25 X 30MM
19	1	1177	SPRING GATE PIVOT 3/8				
20	2	821	PIN GATE PIVOT 3/8 SMALL				
21	1	1043	SHAFT ROLLER				
22	2	624	NYLOC 1/4-28				
23	1	1042	ROLLER ASSY				
24	1	635	1/4 WASHER AN960C416				
25	1	1035	SHIFT CAM MEDIUM				
26	1	1037	BUSHING CAM				
27	1	1038	WASHER CAM				
28	2	1039	SHIM-CAM				
29	1	1036	CAM ECCENTRIC DRILLED				
30	1	574.1	BOLT HEX HD 1/4-20 X 1 PATCH				
31	2	574	BOLT HEX HD 1/4-20 X 3/4 PATCH				
32	1	1170	SPRING GATE BUMPER				
33	1	1169	GATE BUMPER				
34	1	559.2	FIL HD SLOTTED 10-32 X 1 1/4 PATCH				
35	1	1145	SHAFT ASSY COMPLETE, AE, 14T				
	1	1144	SHAFT ONLY, AE, 14T, 23 1/4 LG				
36	1	41	SHAFT BEARING THRUST RING				
37	1	477	COLLAR BACKFIT 7205				
38	1	832	THRUST WASHER				
39	1	504	BEARING 7205B-UA				
40	1	511	TRUARC 5100-98				
41	1	833	SPACER				
42	1	512	TRUARC N5002-212ZD				
43	1	433	UPPER SEAL CARRIER W/SEALS & O RINGS				
44	4	517	SPIROLOX RR-150S				
45	2	506	SEAL INNER				
46	2	507	SEAL OUTER 6324-S				
47	2	526	O RING 568-135 3/32X1 15/16X2 1/8				
48	1	1166	BEARING CARRIER W/SEALS & O RINGS AE				
49	3	521	O RING 568-011 1/16X5/16X7/16				
50	2	637	WASHER SPRING LOCK #10				
51	2	561	FIL HD SLOTTED 10-24 X 5/8				

SIZE	TORQUE
1/4-20 (M6)	8-9 FT-LBS
5/16-18 (M8)	12 FT-LBS
3/8-16 (M10)	22 FT-LBS

SHIFT ROD ASSY 1385, 1491, SEE PAGE 17

BEARING, SEAL, SNAP & "O" RING KIT 803.1

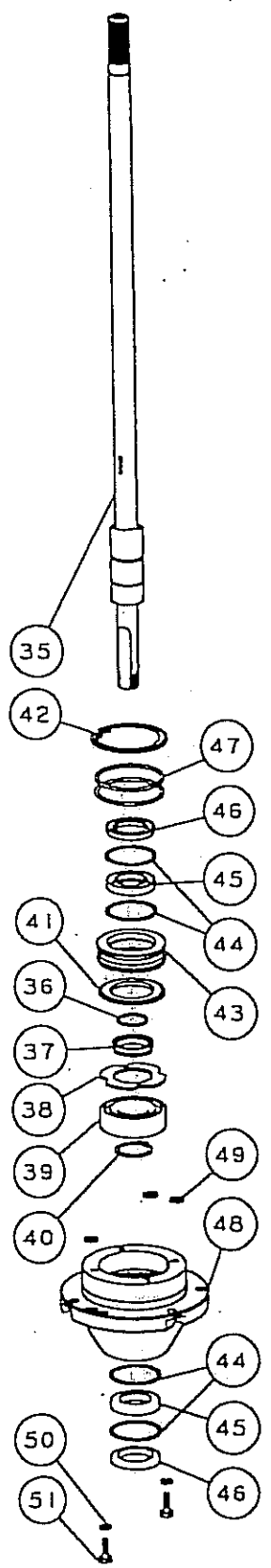
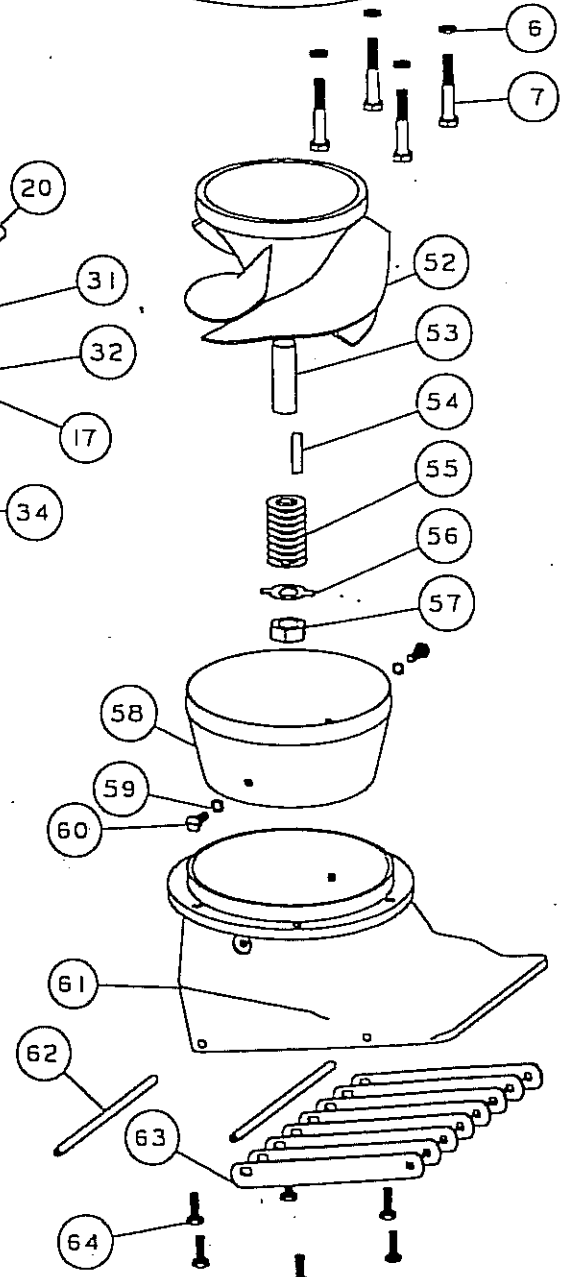
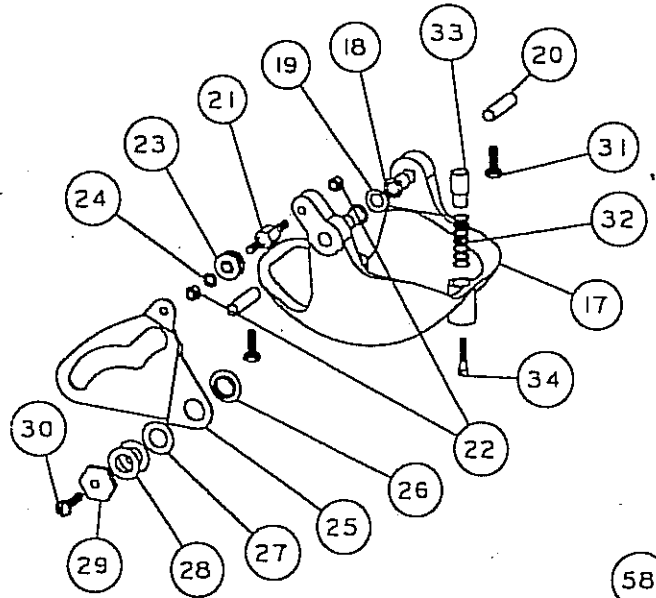
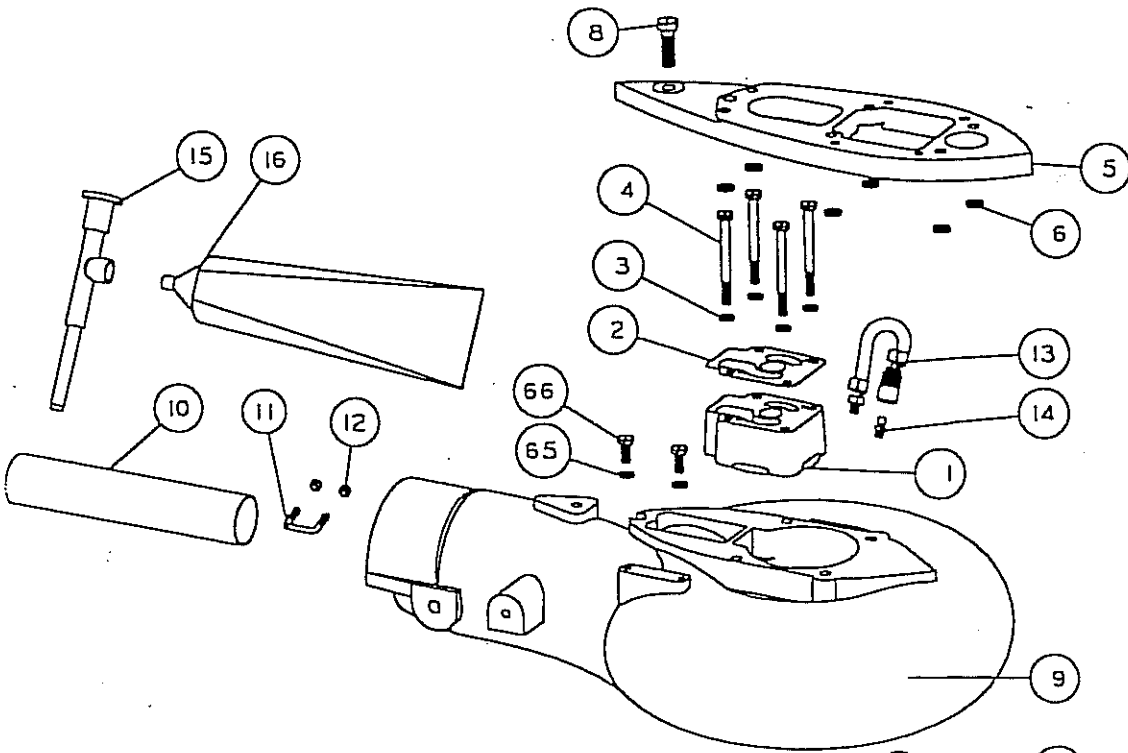

MODEL AE40 TOHATSU/NISSAN

REF	QTY	PART NO	DESCRIPTION	REF	QTY	PART NO	DESCRIPTION
1	1	1138	PUMP ADAPTER AE	52	1	414	IMPELLER 6-79 W/36 SLEEVE 40 HP
2	1	1139	GASKET WATER PUMP AE	53	1	36	SHAFT SLEEVE PLASTIC MEDIUM
3	4	635	1/4 WASHER AN960C416	54	1	782	IMPELLER TEE KEY
4	4	581	BOLT HEX HD 1/4-20 X 2 3/4	55	9	21	SHIM WASHER MEDIUM
5	1	1384	ADAPTER PLATE AE40	56	1	805	NUT KEEPER MED/PKG 2 PER BAG
6	10	640	WASHER SPRING LOCK 5/16	57	1	22.1	SHAFT NUT 5/8-18 BRASS
7	4	595	BOLT HEX HD 5/16-18 X 2			224.2	INTAKE ASSY 6 WITH GRILL & LINER
8	1	606	BOLT HEX HD 3/8-16 X 1 1/4	58	1	855	LINER 6 W/HARDWARE
		11470	VOLUTE WITH GATE AE	59	2	638	WASHER SPRING LOCK 1/4
9	1	1148	VOLUTE WITH EXHAUST TUBE AE	60	2	572	BOLT HEX HD 1/4-20 X 5/8
10	1	221	EXHAUST TUBE SMALL 1 1/2	61	1	853	INTAKE PAINTED ONLY
11	1	847	CLIP EXHAUST TUBE 3/4	62	2	216	GRILL ROD SMALL
12	2	621	NYLOC 10-32	63	8	215	GRILL BAR SMALL
13	1	975	LUBE HOSE ASSY	64	6	573	BOLT HEX HD 1/4-20 X 3/4
14	1	539	ZIRC FITTING 1/4-28	65	2	635	1/4 WASHER AN960C416
15	1	550	GREASE GUN	66	2	572	BOLT HEX HD 1/4-20 X 5/8
16	1	552	GREASE 10 OZ TUBE NO.630-AA				
17	1	1355	REVERSE GATE, SMALL				
18	2	535	NYLINER 3/8 10 X 11/16				
19	1	1177	SPRING GATE PIVOT 3/8				
20	2	821	PIN GATE PIVOT 3/8 SMALL				
21	1	1043	SHAFT ROLLER				
22	2	624	NYLOC 1/4-28				
23	1	1042	ROLLER ASSY				
24	1	635	1/4 WASHER AN960C416				
25	1	1035	SHIFT CAM MEDIUM				
26	1	1037	BUSHING CAM				
27	1	1038	WASHER CAM				
28	2	1039	SHIM - CAM				
29	1	1036	CAM ECCENTRIC DRILLED				
30	1	574.1	BOLT HEX HD 1/4-20 X 1 PATCH				
31	2	574	BOLT HEX HD 1/4-20 X 3/4 PATCH				
32	1	1170	SPRING GATE BUMPER				
33	1	1169	GATE BUMPER				
34	1	559.1	FIL HD SLOTTED 10-32 X 1 1/2 PATCH				
		1389	SHAFT ASSY COMPLETE, AE40, 1ST				
35	1	1388	SHAFT ONLY, AE40, 1ST 22 13/16 LG				
		1424	SHAFT ASSY COMPLETE, AE40L, 1ST				
35	1	1423	SHAFT ONLY, AE40L, 1ST 27 13/16 LG				
36	1	41	SHAFT BEARING THRUST RING				
37	1	477	COLLAR BACKFIT 7205				
38	1	832	THRUST WASHER				
39	1	504	BEARING 7205B-UA				
40	1	511	TRUARC 5100-98				
41	1	833	SPACER				
42	1	512	TRUARC N5002-212ZD				
43	1	433	UPPER SEAL CARRIER W/SEALS & O RINGS				
44	4	517	SPIROLOX RR-150S				
45	2	506	SEAL INNER				
46	2	507	SEAL OUTER 6324-S				
47	2	526	O RING 568-135 3/32X1 15/16X2 1/8				
48	1	1166	BEARING CARRIER W/SEALS & O RINGS AE				
49	3	521	O RING 568-011 1/16X5/16X7/16				
50	2	637	WASHER SPRING LOCK #10				
51	2	561	FIL HD SLOTTED 10-24 X 5/8				

26. JUN. 97

SIZE TORQUE

1/4-20 (M6) 8-9 FT-LBS

5/16-18 (M8) 12

3/8-16 (M10) 22

SHIFT ROD ASSEMBLY
 TOHATSU/NISSAN MODEL AE
 1385 SHORT
 1491 LONG

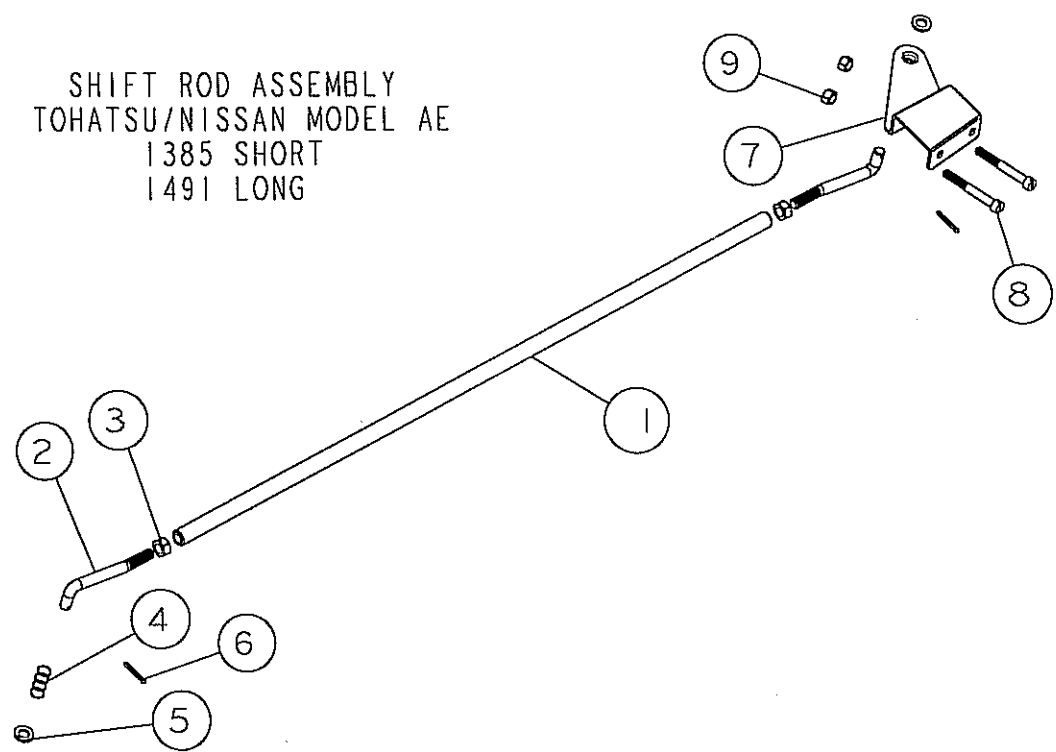

REF	QTY	PART-NO	DESCRIPTION
1	1	480	SHIFT ROD U2-3 18 5/8 SHORT
1	1	492	SHIFT ROD U2L,V,ZLM 23 1/8 LONG
2	2	24	ROD END FORMED
3	2	622	NUT HEX 1/4-28
4	2	1164	SPRING-ROD END
5	2	635	1/4 WASHER AN960C416
6	2	645	COTTER PIN 1/16 X 1/2
7	1	1357	SHIFT LEVER AE CAM
8	2	558.1	FIL HD SLOTTED 10-32 X 1 1/2
9	2	621	NYLOC 10-32

5. AUG. 97