

MODEL AI SERIES

ASSEMBLY INSTRUCTIONS

Honda 35-45 HP, 3 cylinder, 1991 to present

(Motor must have modified crankshaft gearset approx. 1:1 ratio)

1. Place the motor on the transom of your boat so that it is mounted vertically. Disconnect the gearshift rod coupling nut. Remove the 5 bolts and lower the gearbox.
2. Remove the water pump assembly including the lower stainless steel plate and impeller drive key.
3. Install the jet driveshaft assembly into the spiral pump housing locking it in place with the 4 - 1/4-20 x 3/4 bolts and lockwashers. Use grease on the threads.
4. Install the water pump impeller on top of the stainless steel plate and 1-7/16 inch thick aluminum adapter being sure the impeller drive key and dowel pins are in place. Slide the pump housing over the impeller while rotating the shaft. A light film of grease inside the pump chamber helps. Lock in place using 4 - 1/4-20 x 2-1/2 bolts and 1/4 flat washers. Grease the threads.
5. Attach the 3/4 inch adapter plate to the exhaust housing using 4 - M10 x 35MM, 1 - M8 x 30MM bolts with lockwashers and 2 - 6 x 16MM dowel pins. Grease the threads.
6. Next, attach the jet drive to the motor. Use 2 - 3/16 dowel pins, 2 5/16-18 x 2-1/2 bolts (front) and 2 - 5/16-18 x 2-3/4 bolts (rear) with lockwashers, and 1 3/8-16 x 1-1/4 bolt from above rear. Grease the bolt threads, driveshaft spline generously, rubber water tube sleeve and guide the jet into place. Tighten the 5 bolts.
7. Next, install the impeller. Grease the shaft threads, key and impeller bore. Place the plastic sleeve inside the impeller, hold the key in the nose of the impeller with your forefinger and slide onto the driveshaft. Install the nine shim washers and nut retainer on the shaft, up against the impeller, and bring the nut up snug by hand. Be careful that the retainer does not fall into the thread groove and jam the nut.
8. Place the water intake in position and secure with 2 bolts. Observe the clearance between the impeller blade edge and the intake liner. Then remove the intake.

When, after use in sand and gravel, the blade clearance becomes more than about 1/32" between the impeller edge and the water intake liner, one or more of the stainless shim washers can be transferred from the bottom stack to the top of the impeller, which moves the impeller down into the tapered casing to reduce the clearance.

Shims should not be used above the impeller on new installations, where no wear has occurred, unless the blade clearance exceeds 1/32". Insufficient blade clearance will do more harm than good from any performance gains it might provide.

MODEL AI

When the impeller clearance is satisfactory, bump the nut up snug with a wrench. If the ears of the retainer do not line up with the flats on the nut, spin the nut off, turn the retainer over and tighten the nut again. In one of these two positions you will have alignment and can fold the ears up against the nut to retain it. The flat in the retainer is angled to the ears to allow this.

9. Place the intake casing in position with the lower end at the rear and tighten the six 1/4-20 x 3/4 hex head bolts. No lockwashers are used. Grease the threads. See diagram page 3.
10. If your jet drive was ordered for use with a steering tiller handle, see attached page 4, "Shift Cable and Handle Assembly Instructions." Operation of the shift handle on the motor provides neutral start protection.

CAUTION If your motor is equipped for remote controls, 2 cables will be attached to the cable anchor bracket and roller cam, to provide neutral start protection. The outer cable comes from the remote control box to operate the reverse gate. It does not enter the motor housing. The shorter inner cable enters the motor housing to operate the neutral start safety switch and is driven by the movement of the reverse gate. The neutral start switch prevents starting the motor in forward or reverse.

11. With the shift handle in forward and the reverse gate in forward, with the cam roller at the end of the slot, adjust the cable end and/or cable anchor position to this condition. Shift to reverse and back to forward. The roller should be at the end of the cam slot such that the gate cannot be forcibly rotated toward reverse. Pull on the gate by hand to verify this.

Shift to neutral and adjust the cable end in the motor housing so that the neutral start switch is activated. (Remote control only)

12. When converting to jet drive, your motor will have to be raised to height shown in diagram on page 3, using a straight edge under the boat. Test run the boat and then raise or lower the motor 5/16 inch at a time to obtain the best results.

The motor has four sets of upper mounting holes. You will use one set to begin with. Mark pencil lines on the boat transom through the other sets. Then if you wish to go up or down 5/16 inch, you can drill one alternate set of holes 5/16 inch up or down from the pencil marks. By alternating between these two sets of transom holes and the four sets of motor holes, the motor can be moved in 5/16 inch increments over almost one inch. The transom height should be about 21" measured vertically from the boat bottom for short shaft motors and 26" for long shaft.

If you raise it too much it will suck air and cavitate, either on start up or when banking on turns. When cavitating, the motor overspeeds in spurts and shakes considerably in the motor mount. This is not a normal condition and should be avoided by proper adjustment of motor height on each individual boat. If you lower it too much you will have excessive drag, therefore mount the motor as high as possible without allowing cavitation.

MODEL AI

CAUTION

When starting the engine for the first time, watch to see that cooling water comes out of the small hole at the rear side of engine just below the powerhead. This is to check your assembly of the cooling water pump and its connections.

The cooling system can be flushed by removing the slotted screw next to the grease fitting. A hose coupling No. 24789A1 is available from a Mercury dealer. Turn on the water gently, start the motor, set to idle and watch for cooling water at the tell tale. Adjust water pressure if needed. Replace the screw after flushing.

MAINTENANCE AND LUBRICATION

See separate sheet

GOOD BOATING AND HAVE FUN!

PROPER ENGINE HEIGHT

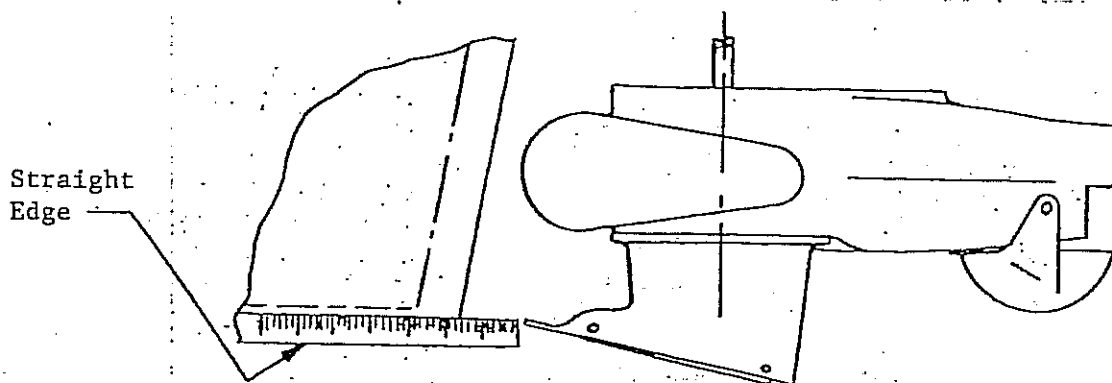

Specialty Manufacturing Company
OUTBOARD JETS
2035 Edison Avenue
San Leandro, CA 94577

MAINTENANCE AND LUBRICATION OUTBOARD JET DRIVE

BEARING LUBRICATION

A grease gun and tube of grease is supplied with your jet drive. We recommend greasing the bearing every 10 hours. Make greasing a part of your cleanup after the days use. Pump in just enough grease to fill the lube hose. Then reconnect the lube hose coupling to the zerk grease fitting.

Every 30-40 hours, pump in extra grease so as to purge any moisture. The texture of the grease coming out gives an indication of conditions inside the bearing housing. A gradual increase in moisture content indicates seal wear. If the grease begins to turn dark, dirty gray, the bearing and seals should be inspected and replaced if necessary. Some discoloration of the grease is normal during the break in period on new sets of seals.

We have selected a water resistant grease of the proper consistency for this application. If you use a substitute grease, be sure it is water resistant and of the same consistency.

IMPELLER

Your jet drive is equipped with a key to protect the unit in the event of a rock jam. This can be reached by removing the water intake, and then the driveshaft nut, similar to a propeller drive. After replacing the key, pull the shaft nut up tight to remove any play between the impeller and shaft. Note the position of the impeller shim washers, and replace them in the same order.

REVERSE GATE MECHANISM

Occasionally check adjustment of the gate shifting linkage. In "forward" the gate should be firmly locked in position. Pull on the gate by hand to verify this. This will prevent wave action from accidentally shifting the gate into reverse as the boat is violently maneuvered

GENERAL

Check all mounting bolts, intake screws, linkage connections, etc., occasionally to be sure they are tight.

SALT WATER USE

Aluminum and stainless steel have been used in the construction of your jet drive. These materials have either been treated or are inherently resistant to corrosion. It is recommended, however, that when not in use the motor be tipped up so that the jet unit is out of the water. When used in salt water more than in fresh water, remove mounting hardware, grease, and reassemble once a year. Failure to do this may result in hardware that is difficult if not impossible to remove at a later date.

GUARANTEE

Due to inflexible government regulation, we do not have a written warranty. We have, however, a good reputation for fairness with our customers which we intend to maintain. If you think you have a warranty situation, regarding material, workmanship, call us before making repairs.

Specialty Manufacturing Company
Outboard Jets
2035 Edison Avenue
San Leandro, CA 94577

SHIFT CABLE ASSEMBLY
HONDA MODEL AIM
TILLER STEERING
30 SHORT
31 LONG

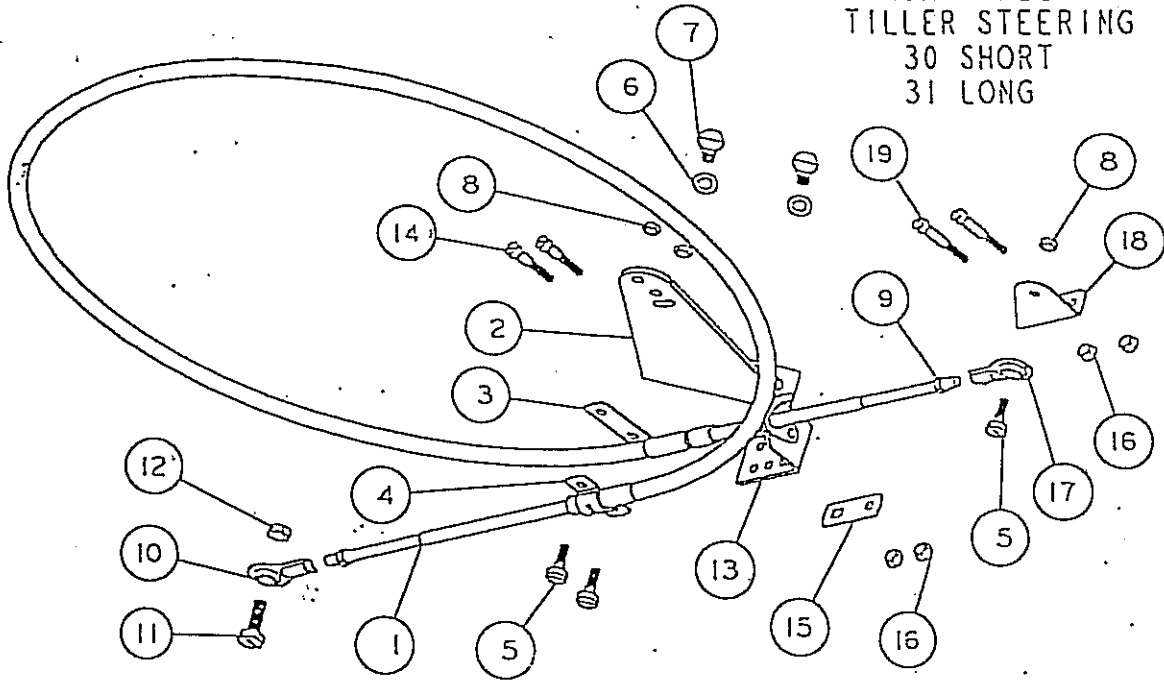

REF	QTY	PART NO	DESCRIPTION
1	1	555	CABLE 3 FT MOR 33C SUPREME SHORT
1	1	549	CABLE 3 1/2 FT MOR 33C SUPREME LONG
2	1	156	BRACKET CABLE SUPPORT
3	1	542	SHIM MORSE A035777
4	1	543	CLAMP CHRYS 154317
5	3	561	FIL HD SLOTTED 10-24 X 5/8
6	2	635	1/4 WASHER AN960C416
7	2	572	BOLT HEX HD 1/4-20 X 5/8
8	3	619	NYLOC 10-24
9	2	621.1	HEX NUT 10-32 JAM
10	1	553.2	BALL END 1/4X10-32 CABLE
11	1	573	BOLT HEX HD 1/4-20 X 3/4
12	1	623	NYLOC 1/4-20
13	1	543.1	CABLE ANCHOR MORSE 36174
14	2	559	FIL HD SLOTTED 10-32 X 1
15	1	542.1	SHIM MODIFIED HONDA
16	4	621	NYLOC 10-32
17	1	553.1	BALL END No. 10X10-32 CABLE
18	1	131.1	SHIFT LEVER HONDA
19	2	558	FIL HD SLOTTED 10-32 X 1 1/4

25.AUG.97

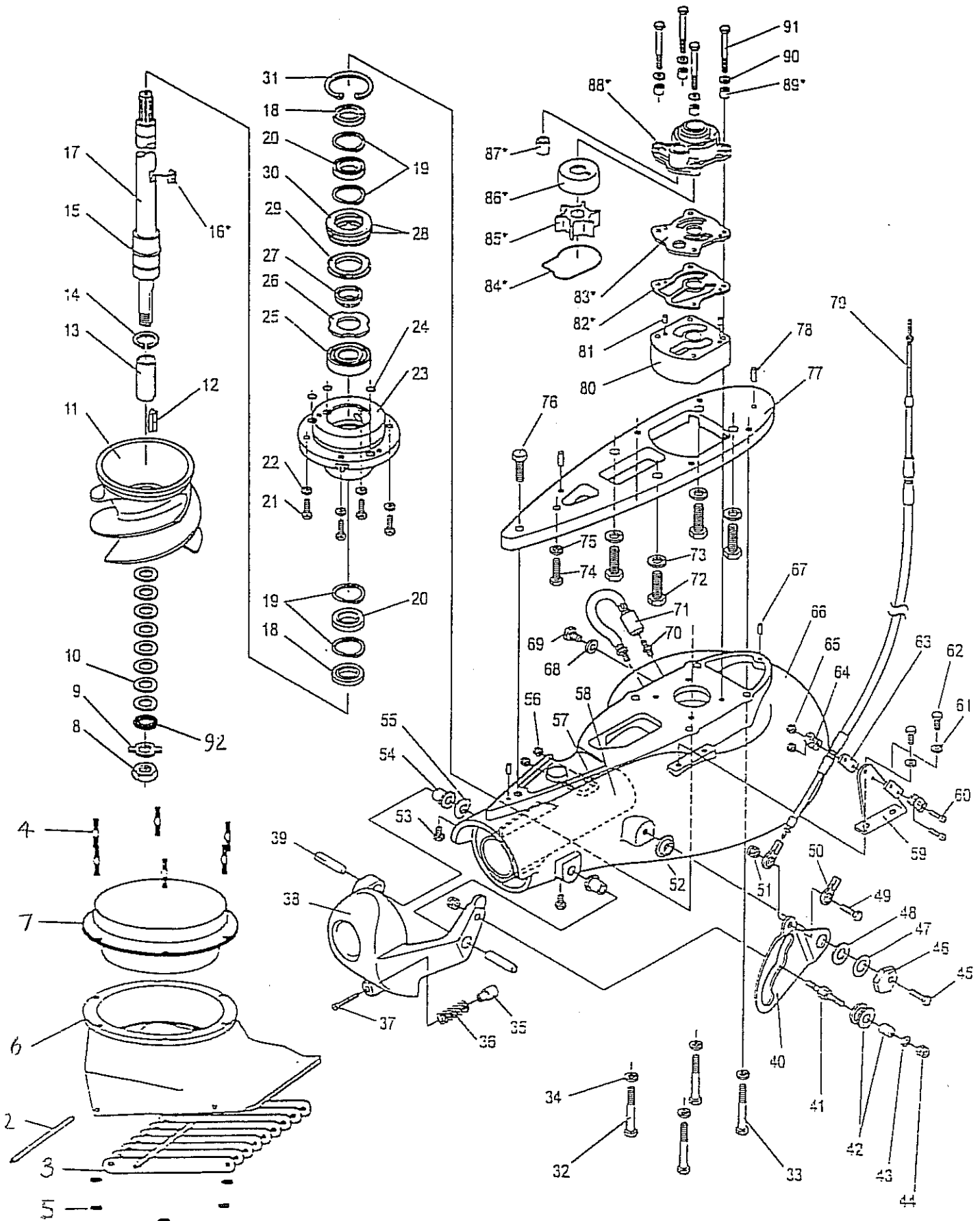

* Provided with outboard motor

MODEL A1

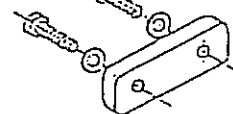

ANODE KIT 1693

MODEL AI HONDA 50 HP

REF	QTY	PART NO.	DESCRIPTION	REF	QTY	PART NO.	DESCRIPTION
2	2	14	GRILL ROD	48	1	1038	NYLON CAM WASHER
3	9	16	GRILL BAR MEDIUM	49	1	576	HEX HD BOLT 1/4-20 X 1" LONG
4	6	1300	STUD - INTAKE MEDIUM	50	2	553.2	CABLE ROD END, 1/4" BALL HOLE
5	6	623	NYLOC 1/4-20	51	1	623	FIBER LOCK NUT 1/4-20
6	1	1326	INTAKE PAINTED ONLY MED FLANGED	52	1	1037	CAM BUSHING
		1447	INTAKE ASSY 6 1/8 FLANGED W/ GRILL & LINER	53	2	574	NYLON HEX HEAD BOLT, 1/4-20 X 3/4" LONG
7	1	1521	LINER 6 1/8 FLANGED	54	2	535	NYLON SLEEVE
8	1	22.1	BRASS DRIVE SHAFT NUT	55	1	1177	WAVE WASHER SPRING
9	1	805	NUT KEEPER, 5/8	56	2	621	FIBER LOCK NUT, #10-32
10	8	21	SHIM WASHER	57	1	846	EXHAUST TUBE CLIP
11	1	8.23	IMPELLER, 6 1/8, ALUM ZINC, 45-50HP	58	1	80	EXHAUST TUBE, 2"
11	1	1737	IMPELLER, 6 1/8, STAINLESS, 45-50HP	59	1	166	CABLE SUPPORT BRACKET
12	1	782	IMPELLER TEE KEY, SQUARE	60	2	561.1	SCREW, #10-24 X 3/4" LONG
12	1	1705	IMPELLER TEE KEY, 1/2 ROUND	61	2	635	PLAIN WASHER, 1/4"
13	1	36	IMPELLER SHAFT SLEEVE	62	2	572	HEX HD BOLT 1/4-20 X 5/8" LONG
14	1	511	RETAINING RING	63	2	542	SHIM
15	1	41	DRIVESHAFT BEARING THRUST RING	64	2	543	CLAMP
16	1		WATER PUMP IMPELLER KEY	65	2	619	FIBER LOCK NUT, #10-24
17	1	1303	DRIVESHAFT, AI SHORT 15" MOTOR	66	1	1309.05	MAIN HOUSING WITH EXHAUST TUBE, AI
17	1	1360	DRIVESHAFT, AI LONG 20" MOTOR	67	2	631	DOWELL PIN 3/16" X 1/2" LONG
	1	1304	DRIVESHAFT ASSY, READY TO INSTALL-SHORT	68	1	1023	SEALING WASHER-COOLING FLUSH
	1	1361	DRIVESHAFT ASSY, READY TO INSTALL-LONG	69	1	1022	HEX HEAD BOLT, 3/8-16 x 1/2" (FLUSH PLUG)
18	2	507	OUTER DRIVESHAFT SEAL	70	1	539	GREASE FITTING
19	4	517	SPIROLOX RETAINING RING	71	1	975	LUBE HOSE ASSEMBLY
20	2	506	INNER DRIVESHAFT SEAL	72	4	592	HEX HEAD BOLT, 10 X 35 MM
21	4	573	HEX HEAD BOLT, 1/4-20 X 3/4" LONG	73	4	636	SPRING LOCK WASHER 10MM
22	4	638	SPRING LOCK WASHER, 1/4	74	1	591	HEX HEAD BOLT, 8 X 30 MM
23	1	1315	BEARING CARRIER W/SEALS "O" RINGS	75	1	640	SPRING LOCK WASHER 8 MM
24	3	521	O-RING, 1/16 X 5/16 X 7/16-011	76	1	606	HEX HEAD BOLT, 3/8-16 x 1 1/4" LONG
25	1	504	SINGLE ROW BEARING	77	1	1305	ADAPTER PLATE, AI
26	1	832	THRUST WASHER	78	2	616	DOWELL PIN, 6 X 16 MM
27	1	477	COLLAR	79	1	547.2	NEUTRAL CABLE, 5 FT
28	2	526	O-RING, 3/32 X 1 15/16 X 2 1/8 - 135	80	1	1306	PUMP ADAPTER AI
29	1	833	SPACER	81	2	616.5	DOWEL PIN, 4 X 8 MM
30	1	433	UPPER SEAL CARRIER W/SEALS & "O" RING	82*	1		WATER PUMP IMPELLER GASKETT B
31	1	512	RETAINING RING	83*	1		WATER PUMP IMPELLER COVER
32	2	599	HEX HEAD BOLT, 5/16-18 X 2 3/4" LONG	84*	1		WATER PUMP O-RING
33	2	603	HEX HEAD BOLT, 5/16-18 X 2 1/2" LONG	85*	1		WATER PUMP IMPELLER
34	4	640	SPRING LOCK WASHER, 5/16	86*	1		WATER PUMP LINER
35	1	1169	GATE BUMPER	87*	1		WATER TUBE SEAL RING
36	1	1170	BUMPER SPRING	88*	1		WATER PUMP IMPELLER HOUSING
37	1	559.2	SCREW, #10-32 X 1 1/4" LONG	89*	4		WATER PUMP IMPELLER HOUSING COLLAR
38	1	1175.05	REVERSE GATE	90	4	635	PLAIN WASHER 1/4"
39	2	822	REVERSE GATE PIVOT PIN, 3/8 X 1 13/16" LONG	91	4	584	HEX HEAD BOLT, 1/4-20 X 2 1/2: LONG
40	1	1036	SHIFT CAM	92	1	1718	TORSIONAL DAMPER 5/8
41	1	1043	ROLLER SHAFT				
42	1	1042	CAM GATE ROLLER ASSEMBLY				
43	1	635	PLAIN WASHER, 1/4				
44	2	624	FIBER LOCK NUT 1/4-28				
45	1	574.1	NYLON LOCK HEX HEAD BOLT, 1/4-20X1" LONG				
46	1	1036	ECCENTRIC CAM				
47	1	1039	CAM SHIM				

*PROVIDED WITH OUTBOARD MOTOR

SIZE	TORQUE
1/4-20 (M6)	8-9 FT-LBS
5/16-18 (M8)	12 FT-LBS
3/8-16 (M10)	22 FT-LBS

TILLER STEERING

SHIFT CABLE ASSY 30, 31 SEE PAGE 30
SHIFT CABLE ASSY 1828, SEE PAGE 34.3

REMOTE CONTROL

NEUTRAL SWITCH CABLE ASSY 1318 SEE PAGE 31

BEARING, SEAL, SNAP & "O" RING KIT 803.1

MODEL AI

Shift Cable and Handle Assembly Instructions

1. Place the pressed steel shift cable end bracket on the motor shift handle over a piece of masking tape. Position as shown below and mark the hole positions with a pencil. Using a 3/16 inch drill, drill through the shift handle for the #10-32 x 1-1/4 screws. Remove the tape and install the screws and fiber lock nuts.
2. Cut out the paper template below for the cable anchor and position on the motor (see photo). Center punch, through the paper, the hole locations and drill 2-3/16 inch holes through. Mount the cable anchor bracket using 2 #10-32 x 1 screws, fiber lock nuts and lower metal plate to support the nuts. You may wish to file the sharp rear edge of the bracket.
3. With the shift handle in forward and the reverse gate in forward, with the cam roller at the end of the slot, adjust the cable end and/or cable anchor position to this condition. Shift to reverse and back to forward. The roller should be at the end of the cam slot such that the gate cannot be forcibly rotated toward reverse. Pull on the gate by hand to verify this.

