

## MODEL AM SERIES

### ASSEMBLY INSTRUCTIONS

For Johnson/Evinrude 3 cylinder 25/35HP 30.5/34.5 cu. in. starting 1996.

1. Place the engine on the transom of your boat so that it is mounted vertically, in the normal fashion.
2. Remove the two screws and water inlet screens from the gearbox. Back off the nut at the lower end of the shift rod. Slide the nut up and remove the split plastic ferrule followed by the nut. Remove the six bolts holding the gearbox and lower the gearbox.
3. The shift rod, which now hangs below the exhaust housing mounting face, would interfere with the jet drive and must be shortened. A holding clamp, part no.1478, is available from the factory to hold the rod for cutting and threading. The rod needs to be threaded only if you wish to change back to propeller drive at a later date.

Slide the clamp up on the shift rod with the clamp slot all the way up on the exhaust housing rib. Tighten the rib bolt, shift the rod to its lowest position and firmly tighten the two bolts against the rod. With a hacksaw, cut exactly 3 1/2 inches off the end of the rod. Using a file, bevel the sharp edges of the rod. Save the cut off section of rod. Remove the clamp.

4. If you wish to change back to the propeller drive at a later date, we have available a threading die kit and threaded coupling with instructions for threading the cut off ends of the shift rod. This will make it easy to switch back and forth between prop and jet. The stainless steel coupling costs extra and the cost of the threading kit is refundable after return in good condition. Tool #465, Coupling #464.
5. Next, install the jet pump drive shaft assembly into the spiral pump housing locking it in place with two #10-24 fillister head screws and spring lockwashers.
6. Remove the water pump assembly from the gearbox, including drive key, stainless pump plate, and gasket. Install this assembly in the jet drive. Be sure the pump is in good condition and that the rubber impeller fingers are all pointing backwards when turning the driveshaft in a clockwise direction looking down from above. Don't forget the impeller drive key. Remove the rubber sealing cap from the top of the water pump. Install the brass water tube extension and aluminum shaft shield extension. A little grease on the "O" rings will ease assembly. Install the rubber cap on top of the extensions.
7. A 3/4" adapter plate is attached to the exhaust housing to hold the jet drive. Remove any excess gasket cement from the face of the exhaust housing to provide a flat surface. Install the adapter plate using the six bolts from the gearbox. Tighten to 12 Ft-Lbs.
8. Next, attach the jet drive to the motor. Use four 5/16-18 x 2 3/4 bolts with lock washers from below and one 3/8-16 x 1 1/4 bolt from above at the rear. Grease the bolt threads, driveshaft spline and shift rod. Tighten the 5/16 bolts to 12 Ft-Lbs and the 3/8 bolt to 18 Ft-Lbs.
9. Next, install the impeller. Grease the shaft threads, key and impeller bore. Place the plastic sleeve inside the impeller, hold the key in the nose of the impeller with your forefinger and slide onto the driveshaft. Install the eight shim washers and nut retainer on the shaft, up against the impeller, and bring the nut up snug by

MODEL AM

hand. Be careful that the retainer does not fall into the thread groove and jam the nut.

Place the water intake in position and secure with two bolts. Observe the clearance between the impeller blade edge and the intake liner. Then remove the intake.

When, after use in sand and gravel, the blade clearance becomes more than about 1/32" between the impeller edge and the water intake liner, one or more of the stainless shim washers can be transferred from the bottom stack to the top of the impeller, which moves the impeller down into the tapered casing to reduce the clearance.

Shims should not be used above the impeller on new installations, where no wear has occurred, unless the blade clearance exceeds 1/32". Insufficient blade clearance will do more harm than good from any performance gains it might provide.

When the impeller clearance is satisfactory, bump the nut up snug with a wrench. If the ears of the retainer do not line up with the flats on the nut, spin the nut off, turn the retainer over and tighten the nut again. In one of these two positions you will have alignment and can fold the ears up against the nut to retain it. The flat in the retainer is angled to the ears to allow this.

10. Place the intake casing in position with the lower end at the rear and tighten the six 1/4-20 x 3/4 hex head bolts. No lockwashers are used. Grease the threads. See diagram pg. 3.
11. If your jet drive was ordered for use with a steering tiller handle, see attached page "Shift Cable and Handle Assembly Instructions," pages 4-5.
12. If your motor is equipped for remote controls, proceed as follows:

Attach the shift cable and cable anchor bracket to the jet drive. With the shift handle in forward and the reverse gate in forward, with the cam roller at the end of the slot, adjust the cable end and/or the cable anchor position to this condition. Shift to reverse and back to forward. The roller should be at the end of the cam slot such that the gate cannot be forcibly rotated toward reverse. Pull on the gate by hand to verify this.

13. When converting to jet drive, your motor will have to be raised to the height shown in the diagram pg. 3, using a straight edge under the boat. Test run the boat and, then raise or lower the motor 5/16 " at a time to obtain best results.

If you raise it too much it will suck air and cavitate, either on start up or when banking on turns. When cavitating, the motor overspeeds in spurts and shakes considerably in the motor mount. This is not a normal condition and should be avoided by proper adjustment of motor height on each individual boat. If you lower it too much you will have excessive drag, therefore mount the motor as high as possible without allowing cavitation.

**CAUTION** When starting the motor for the first time, watch to see that cooling water comes out of the small hole at the rear side of the cowling just below the powerhead. This is to check your assembly of the cooling water pump and its connections.

MAINTENANCE AND LUBRICATION

See last page.

GOOD BOATING AND HAVE FUN!

PROPER ENGINE HEIGHT

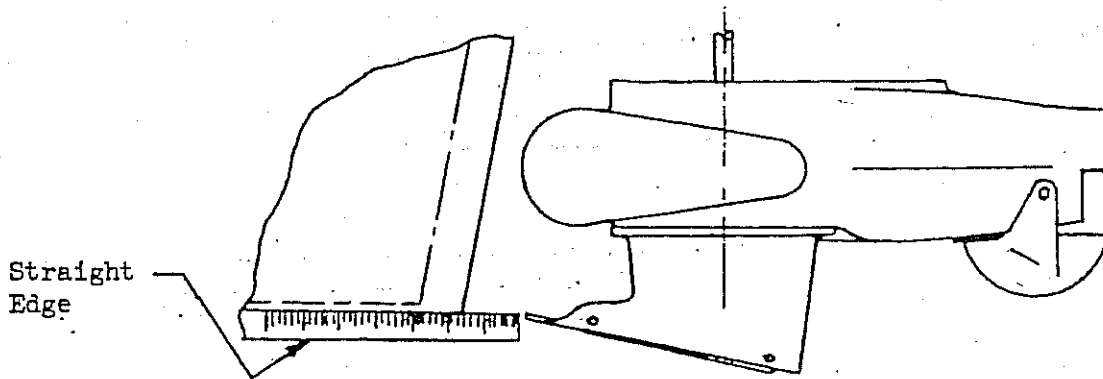

Specialty Manufacturing Company  
Outboard Jets  
2035 Edison Avenue  
San Leandro, CA 94577

## MODEL AM TILLER HANDLE STEERING

Shift Cable Assembly 1479 Short Shaft Motors, 1480 Long Shaft Motors.

1. Cut out the drilling template. Place the template on the motor cowl, align top edge flush and forward against rubber cutout. Hold in place with masking tape. Center punch holes and drill through using a 3/16 drill. Remove the template.
2. To adapt the shift handle, remove the spring clip holding the cross pin through the shift rod. Slide out the pin and remove the pivot bolt and spring washer. Install the hex pivot shaft with spring washer and tighten. Slide the threaded cross pin through the shift handle and shift rod. Attach the stamped shift lever. Tighten the 1/4-20 nut and then back off one quarter turn to allow the shift handle to rotate freely. Tighten the #10 nut only enough to take end play out of the cross pin.
3. Attach the lower cable anchor to the jet drive and the upper cable anchor to the motor cowl.
4. Place the reverse gate in forward with the cam roller at the end of the slot in the cam. Place the shift handle in forward. Adjust the cable end fitting and/or the position of the lower cable bracket to satisfy this condition. Lock hardware.
5. Shift to reverse and back to forward. The cam roller should be at the end of the slot in the cam such that the gate cannot be forcibly rotated toward reverse. Pull on the gate by hand to verify this. Readjust if necessary to satisfy this condition.

**CAUTION** You must return the throttle to idle before shifting.

# MAINTENANCE AND LUBRICATION OUTBOARD JET DRIVE

## BEARING LUBRICATION

A grease gun and tube of grease is supplied with your jet drive. We recommend greasing the bearing every 10 hours. Make greasing a part of your cleanup after the days use. Pump in just enough grease to fill the lube hose. Then reconnect the lube hose coupling to the zerk grease fitting.

Every 30-40 hours, pump in extra grease so as to purge any moisture. The texture of the grease coming out gives an indication of conditions inside the bearing housing. A gradual increase in moisture content indicates seal wear. If the grease begins to turn dark, dirty gray, the bearing and seals should be inspected and replaced if necessary. Some discoloration of the grease is normal during the break in period on new sets of seals.

We have selected a water resistant grease of the proper consistency for this application. If you use a substitute grease, be sure it is water resistant and of the same consistency.

## IMPELLER

Your jet drive is equipped with a key to protect the unit in the event of a rock jam. This can be reached by removing the water intake, and then the driveshaft nut, similar to a propeller drive. After replacing the key, pull the shaft nut up tight to remove any play between the impeller and shaft. Note the position of the impeller shim washers, and replace them in the same order.

## REVERSE GATE MECHANISM

Occasionally check adjustment of the gate shifting linkage. In "forward" the gate should be firmly locked in position. Pull on the gate by hand to verify this. This will prevent wave action from accidentally shifting the gate into reverse as the boat is violently maneuvered

## GENERAL

Check all mounting bolts, intake screws, linkage connections, etc., occasionally to be sure they are tight.

## SALT WATER USE

Aluminum and stainless steel have been used in the construction of your jet drive. These materials have either been treated or are inherently resistant to corrosion. It is recommended, however, that when not in use the motor be tipped up so that the jet unit is out of the water. When used in salt water more than in fresh water, remove mounting hardware, grease, and reassemble once a year. Failure to do this may result in hardware that is difficult if not impossible to remove at a later date.

## GUARANTEE

Due to inflexible government regulation, we do not have a written warranty. We have, however, a good reputation for fairness with our customers which we intend to maintain. If you think you have a warranty situation, regarding material, workmanship, call us before making repairs.

Specialty Manufacturing Company  
Outboard Jets  
2035 Edison Avenue  
San Leandro, CA 94577

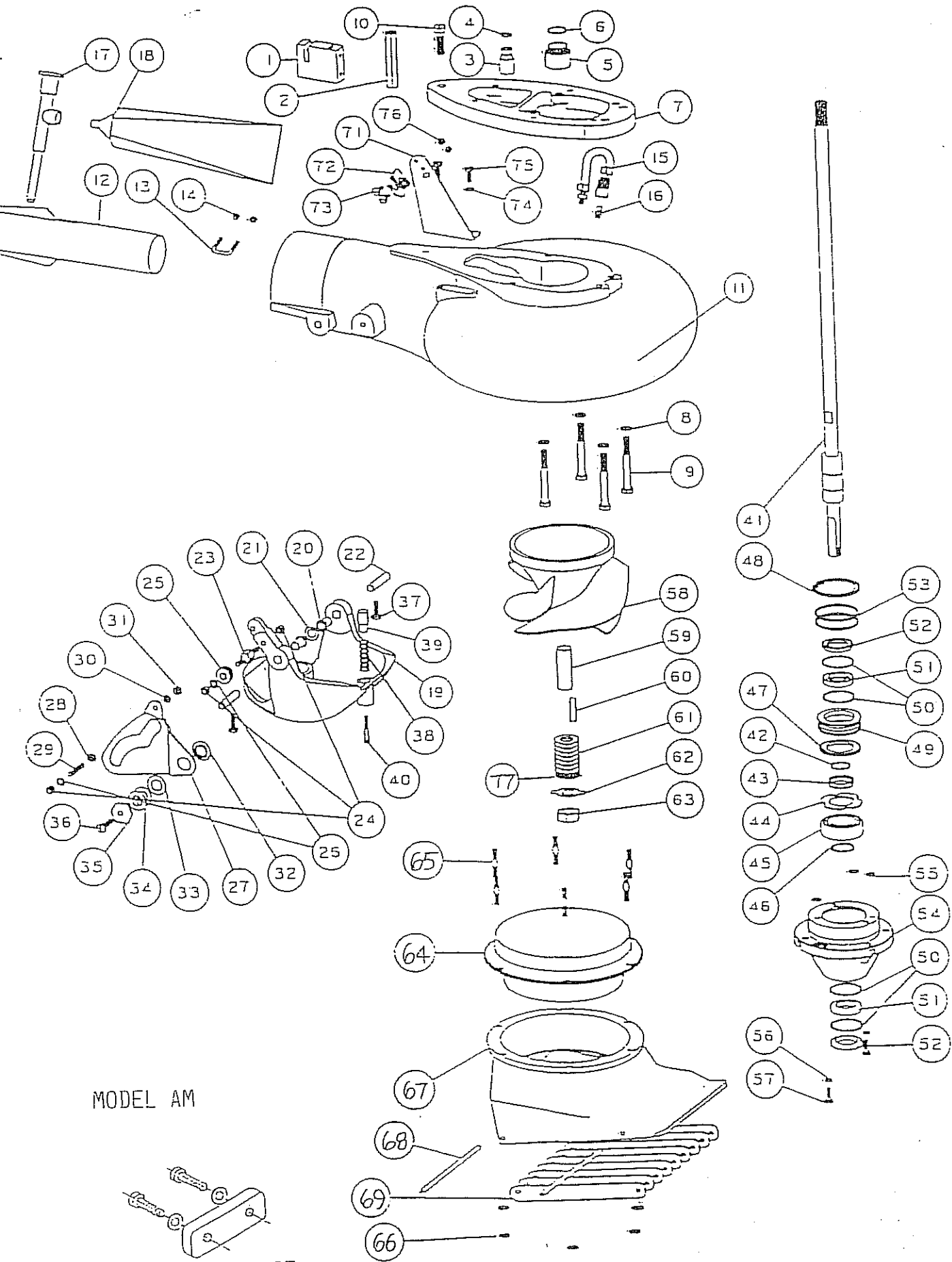

MODEL AM

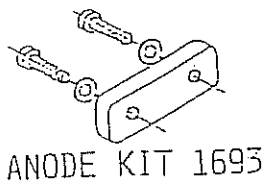

## MODEL AM JOHNSON / EVINRUDE

REF	QTY	PART NO.	DESCRIPTION	REF	QTY	PART NO.	DESCRIPTION
1	1	1478	SHIFT ROD HOLDER TOOL AM	49	1	433	UPPER SEAL CARRIER W/SEALS & O RINGS
2	1	464	SHIFT ROD COUPLING Q	50	4	517	SPIROLOX RR-150S
3	1	1476	WATER TUBE EXT AM W/O-RING	51	2	506	SEAL INNER
4	1	529	O RING 568-013 1/16X7/16X9/16	52	2	507	SEAL OUTER 6324-S
5	1	1477	SHAFT SHIELD EXT AM W/O-RING	53	2	526	O RING 568-135
6	1	532	O RING 568-018 1/16X3/4X7/8	54	1	1472	BEARING CARRIER W/SEALS & O RINGS AM
7	1	1453	ADAPTER PLATE AM	55	3	521	O RING 568-011 1/16X5/16X7/16
8	4	640	WASHER SPRING LOCK 5/16	56	2	637	WASHER SPRING LOCK 1/4
9	4	599	BOLT HEX HD 5/16-18 X 2 3/4	57	2	561	FIL HD SLOTTED 10-24 X 5/8
10	1	606	BOLT HEX HD 3/8-16 X 1 1/4	58	1	8.21	IMPELLER 5 7/8, ALUM/ ZINC, W/36.1 SLEEVE
		1457	VOLUTE WITH GATE AM	59	1	36.1	SHAFT SLEEVE PLASTIC MED.
11	1	1456	VOLUTE WITH EXHAUST TUBE AM	60	1	782	IMPELLER TEE KEY - SQUARE
12	1	80	EXHAUST TUBE ASSY MEDIUM 2	60	1	1705	IMPELLER TEE KEY - 1/2 ROUND
13	1	846	CLIP EXHAUST TUBE 1	61	8	21	SHIM WASHER MEDIUM
14	2	621	NYLOC 10-32	62	1	865	NUT KEEPER MED/PKG 2 PER BAG
15	1	975	LUBE HOSE ASSY	63	1	22.1	SHAFT NUT 5/8-18 BRASS
16	1	539	ZIRC FITTING 1/4-28			1448	INTAKE ASSY 5 7/8 FLANGED W/ GRILL & LINER
17	1	550	GREASE GUN	64	1	1678	LINER 5 7/8 FLANGED
18	1	552	GREASE TUBE NO 630-AA	65	6	1300	STUD - INTAKE MEDIUM
19	1	1175	REVERSE GATE, MEDIUM	66	6	623	NYLOC 1/4-20
20	2	535	NYLINER 3/8 1D X 11/16	67	1	1326	INTAKE PAINTED ONLY MED FLANGED
21	1	1177	SPRING GATE PIVOT 3/8	68	2	14	GILL ROD
22	2	822	PIN GATE PIVOT 3/8 MEDIUM	69	9	16	GILL BAR MEDIUM
23	1	1043	SHAFT ROLLER			170	BRACKET ASSY OMC W/CLIP & HARDWARE
24	3	624	NYLOC 1/4-28	71	1	156	BRACKET CABLE SUPPORT
25	1	1042	ROLLER ASSY	72	1	546	CLIP OMC 305736
26	2	635	1/4 WASHER AN960C416	73	2	562	PAN HD SLOTTED 10-32 X 1/2
27	1	1035	SHIFT CAM MEDIUM	74	2	635	1/4 WASHER AN960C416
28	1	62	NUT HEX JAM 1/4-28	75	2	572	BOLT HEX HD 1/4-20 X 5/8
29	1	1199	PIVOT - CABLE END	76	2	621	NYLOC 10-32
30	1	638	WASHER SPRING LOCK 1/4	77	1	1718	TORSIONAL DAMPER 5/8
31	1	622	NUT HEX 1/4-28				
32	1	1037	BUSHING CAM				
33	1	1038	WASHER CAM				
34	2	1039	SHIM - CAM				
35	1	1036	CAM ECCENTRIC DRILLED				
36	1	574.1	BOLT HEX HD 1/4-20 X 1 PATCH				
37	2	574	BOLT HEX HD 1/4-20 X 3/4 PATCH				
38	1	1170	SPRING GATE BUMPER				
39	1	1169	GATE BUMPER				
40	1	559.2	FIL HD SLOTTED 10-32 X 1 1/4 PATCH				
		1461	SHAFT ASSY COMPLETE, AM SHORT, 14T				
41	1	1460	SHAFT ONLY, AM SHORT, 14T, 24 3/8 LG.				
		1484	SHAFT ASSY COMPLETE, AM LONG, 14T				
41	1	1483	SHAFT ONLY, AM LONG, 14T, 29 3/8 LG.				
42	1	41	SHAFT BEARING THRUST RING				
43	1	477	COLLAR BACKFIT 7205				
44	1	832	THRUST WASHER				
45	1	504	BEARING 7205B-UA				
46	1	511	TRUARC 5100-98				
47	1	833	SPACER				
48	1	512	TRUARC N5002-212ZD				

SIZE	TORQUE
1/4-20 (M6)	8-9 FT-LBS
5/16-18 (M8)	12 FT-LBS
3/8-16 (M10)	22 FT-LBS

TILLER STEERING:

SHIFT CABLE ASSY 1479, 1480, SEE PAGE 34

BEARING, SEAL, SNAP & "O" RING KIT 803.1

## JOHNSON/EVINRUDE SHIFT ROD MODIFICATION

25-35HP 3 Cylinder 1996 - Model AM Jet Drive

1. To install the jet drive, it is necessary to cut the shift rod which extends below the engine exhaust housing mounting flange. The cut ends of the rod can then be threaded to receive a coupling so that the gearbox can be remounted on the engine when desired.
2. Slide the holding clamp (part no.1478) over the shift rod, up around the exhaust housing rib and tighten the rib bolt. Shift the rod to its lowest position and firmly tighten the two bolts against the rod. With a hacksaw, cut exactly 3 1/2 inches off the end of the rod. Using a file, bevel the cut edges of each piece to allow starting the threading die.
3. Use oil on the rod and die. Thread the rod in the motor back 1/2 inch. Watch that the rod does not turn and break the plastic coupling up in the motor.
4. Grip the 3 1/2 inch rod in a vise and thread it back just 3/8 inch, not more. Again, holding the rod in a vise, slide the drilled end of the coupling over the rod and thread it into place, jamming the ends of the threads to lock the coupling permanently to the rod. Replace the lower nut and split plastic ferrule on the rod. Install the rod in the gearbox, leaving the nut loose so that the rod and coupling can be turned to engage the upper shift rod threads when installing the gearbox.
5. When mounting the gearbox, slide the gearbox into place while threading the coupling onto the upper shift rod. Do not overtighten. Lock the lower nut and ferrule which secures the rod from turning.

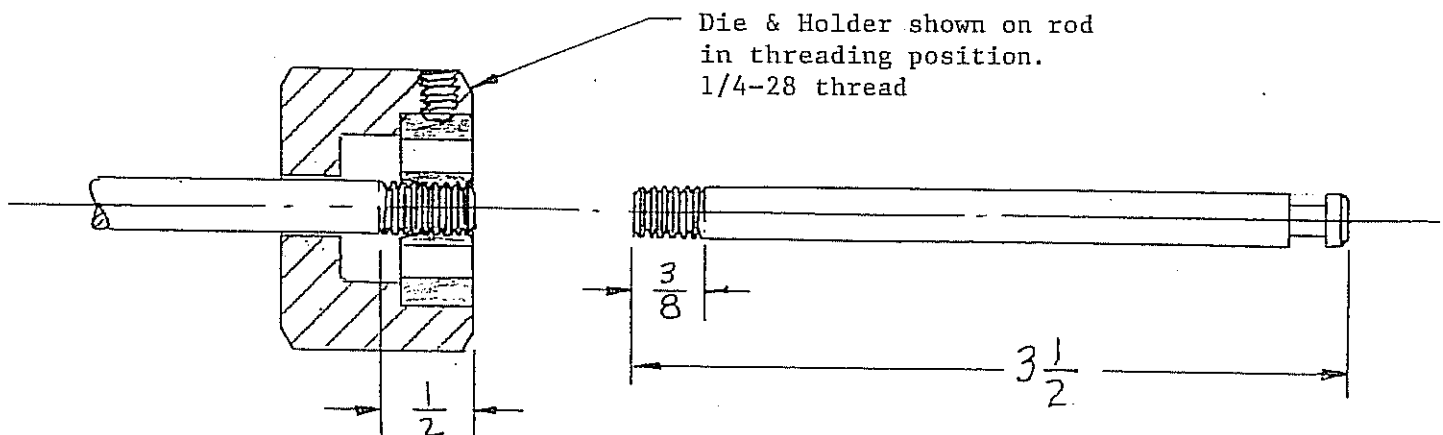

Threading die and holder (part no.465)

Holding clamp (part no.1478)

Coupling (part no.464)

Return after use for refund.

Outboard Jets  
2035 Edison Ave.  
San Leandro, CA 94577

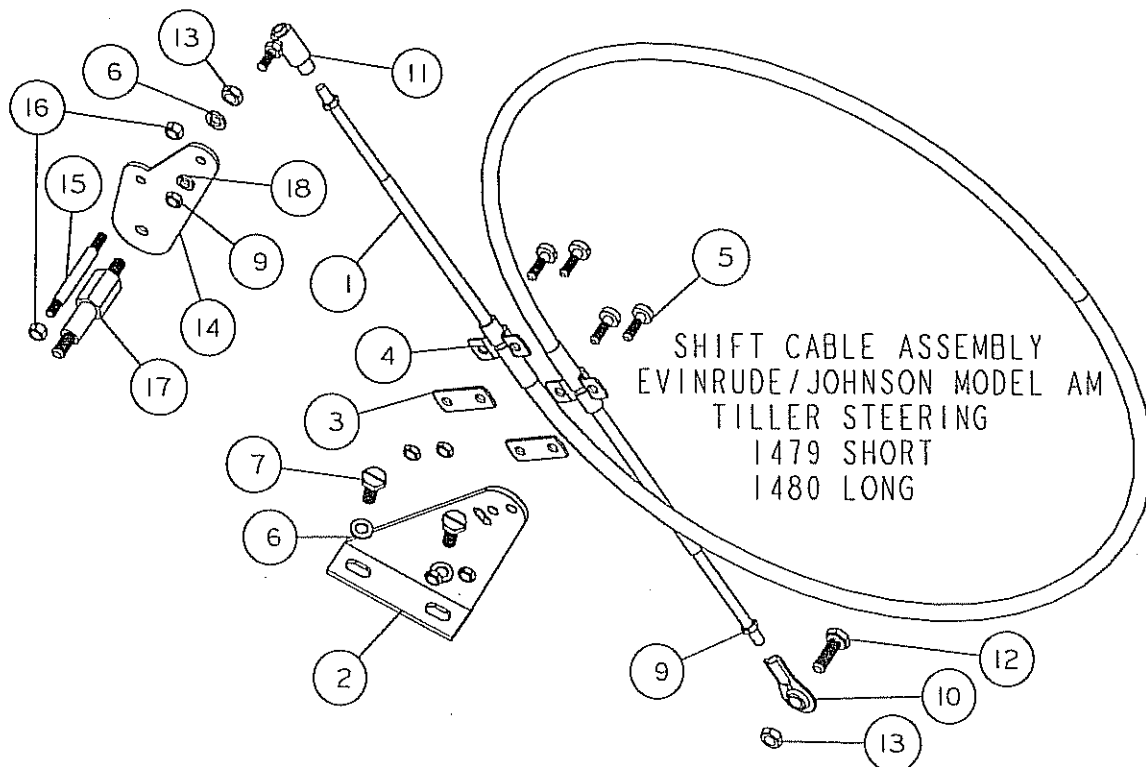

REF	QTY	PART NO	DESCRIPTION
1	1	555	CABLE 3 FT MOR 33C SUPREME SHORT
1	1	549	CABLE 3 1/2 FT MOR 33C SUPREME LONG
2	1	156	BRACKET CABLE SUPPORT
3	2	542	SHIM MORSE A035777
4	2	543	CLAMP CHRYS 154317
5	4	561	FIL HD SLOTTED 10-24 X 5/8
6	3	635	1/4 WASHER AN960C416
7	2	572	BOLT HEX HD 1/4-20 X 5/8
8	4	619	NYLOC 10-24
9	3	621.1	HEX NUT 10-32 JAM
10	1	553.2	BALL END 1/4X10-32 CABLE
11	1	544.1	BALL JOINT MORSE 31799-001
12	1	573	BOLT HEX HD 1/4-20 X 3/4
13	2	623	NYLOC 1/4-20
14	1	1473	SHIFT ARM AM
15	1	1475	PIN - SHIFT ROD AM
16	2	621	NYLOC 10-32
17	1	1474	SHAFT - HANDLE AM
18	1	637	WASHER SPRING LOCK No. 10

6. AUG. 97

