

MODEL AP 90-115, AP140P SUZUKI SERIES
ASSEMBLY INSTRUCTIONS
90-140 HP 4 STROKE 4 CYLINDER

1. Place the engine on the transom of your boat so that it is mounted vertically, in the normal fashion. Remove the bolts holding the gearbox to the exhaust housing. As you lower the gearbox, cut the tie holding the speedometer water pickup rubber tube and slip the tube off of the gearbox fitting. Remove the gearbox assembly.
2. Remove the water pump assembly from the propeller drive, including the lower stainless steel plate, dowel pins, and impeller drive key.
3. Install the jet driveshaft assembly into the spiral pump housing, locking it in place with the four 5/16-18 x 1 bolts with lock washers. Use grease on the threads. Tighten to 12 ft-lbs.
4. Install the 3/4" thick aluminum water pump adapter on the main housing using two 3/16 x 1/2 dowel pins. Using the two 6mm dowel pins, install the water pump assembly on top of the 3/4" thick aluminum adapter and stainless steel plate. Be sure also, to install the water pump impeller drive key removed from the propeller drive. Lock in place using four 5/16-18 x 1 3/4 bolts to 10 ft-lbs. Grease the threads. Do not use the gasket.
5. The large 3/4" adapter plate is attached to the midsection to hold the jet drive. Two 8 x 12mm dowels locate the plate, seven M10 x 35mm bolts with lock washers secure it, 22 ft-lbs. Grease the threads.
6. Next, attach the jet drive to the motor. Two 3/16 x 1/2 dowel pins center the jet drive on the adapter plate. Four 3/8-16 bolts from below and one 3/8-16 x 1 1/2 bolt from above rear with lock washers are used. Select the lower bolt lengths to suit the different counter bore depths so that all bolts enter the adapter plate the same depth.

Grease the bolt threads, driveshaft spline generously, and rubber water tube pilot and guide the jet into place. Tighten the five bolts to 22 ft-lbs.

7. Next, install the impeller. Grease the shaft threads, key and impeller bore. Place the plastic sleeve inside the impeller; hold the key in the nose of the impeller with your forefinger and slide onto the driveshaft. Install the seven shim washers, torsion damper and nut retainer on the shaft, up against the impeller, and bring the nut up snug by hand.

Then bump the nut up snug with a wrench. If the ears of the retainer do not line up with the flats on the nut, spin the nut off, turn the retainer over and tighten the nut again. In one of these two positions you will have alignment and can fold the ears up against the nut to retain it. The flat in the retainer is angled to the ears to allow this.

When, after use in sand and gravel, the blade clearance becomes more than about 1/32" between the impeller edge and the water intake liner, one or more of the shim washers can be transferred from the bottom stack to the top of the impeller, which moves the impeller down into the tapered casing to reduce the clearance.

Shims should not be used above the impeller on new installations where no wear has occurred unless the blade clearance exceeds 1/32 inch. Insufficient blade clearance will do more harm than good from any performance gains it might provide.

MODEL AP 90-115, AP140P SUZUKI SERIES
ASSEMBLY INSTRUCTIONS
90-140 HP 4 STROKE 4 CYLINDER

8. Place the intake casing in position with the lower end at the rear and tighten the six nuts to 12 ft-lbs. No lock washers are used. Grease the threads.
9. The shift cable from the remote control box and a 6 ft cable, which goes to the neutral switch inside motor cowl, both attach to the reverse gate cam. The shift cable is on the outside of the cable anchor bracket and the 6 ft cable is on the inside. See figs 1-3. Mount both cables to the anchor bracket and then attach the bracket to the main housing. Slide the bracket all the way forward and lock the bolts. Screw the ball rod ends on the cables as far as they will go and attach them to straddle the reverse gate cam. Lock the 1/4-20 x 1 bolt and lock nut. Screw the Suzuki cable end onto the 6 ft cable, all the way, and route the cable to the port side of the motor, around the front and connect to the shift linkage.
10. With the shift handle in forward and the reverse gate in forward, with the cam roller at the end of the slot, adjust the cable and/or cable anchor position to this condition. Shift to reverse and back to forward. The roller should be at the end of the cam slot such that the gate cannot be forcibly rotated toward reverse. Pull on the gate by hand to verify this.

Shift to neutral and adjust the cable end in the motor housing so that the neutral start switch is activated. Check adjustment coming from both forward and reverse to compensate free play in cable linkage.

11. When converting to jet drive, your motor will have to be raised to height shown in diagram on page 3, below, using a straight edge under the boat. Test run the boat and then raise or lower the motor 5/16 inch at a time to obtain the best results.

The motor has four sets of upper mounting holes. You will use one set to begin with. Mark pencil lines on the boat transom through the other sets. Then if you wish to go up or down 5/16 inch, you can drill one alternate set of holes 5/16 inch up or down from the pencil marks. By alternating between these two sets of transom holes and the four sets of motor holes, the motor can be moved in 5/16 inch increments over almost one inch. The transom height should be about 26 inches measured vertically from the boat bottom.

If you raise it too much it will suck air and cavitate, either on start up or when banking on turns. When cavitating, the motor over speeds in spurts and shakes considerably in the motor mount. This is not a normal condition and should be avoided by proper adjustment of motor height on each individual boat. If you lower it too much you will have excessive drag, therefore mount the motor as high as possible without allowing cavitations.

MODEL AP 90-115, AP140P SUZUKI SERIES
ASSEMBLY INSTRUCTIONS
90-140 HP 4 STROKE 4 CYLINDER

SETTING MOTOR HEIGHT

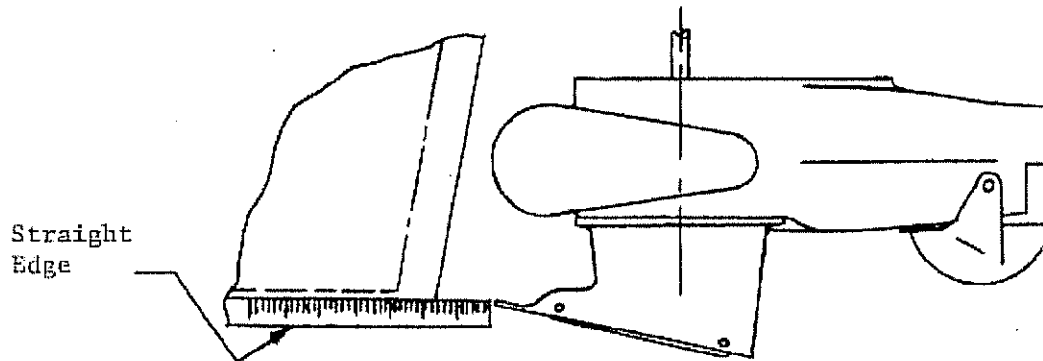

CAUTION

When starting the engine for the first time, watch to see that the cooling water comes out of the small hole at the rear side of the engine just below the power head. This is to check your assembly of the cooling water pump and its connections.

The cooling system can be flushed by removing the slotted screw next to the grease fitting. A hose coupling No. 24789A1 is available from a Mercury dealer. Turn on the water gently, start the motor, set to idle and watch for cooling water at the tell tale. Adjust water pressure if needed. Replace the screw after flushing.

MAINTENANCE AND LUBRICATION

See last page.

MAINTENANCE AND LUBRICATION OUTBOARD JET DRIVE

BEARING LUBRICATION

A grease gun and tube of grease is supplied with your jet drive. We recommend greasing the bearing every 10 hours. Make greasing a part of your cleanup after the days use. Pump in just enough grease to fill the lube hose. Then reconnect the lube hose coupling to the zerk grease fitting.

Every 30-40 hours, pump in extra grease so as to purge any moisture. The texture of the grease coming out gives an indication of conditions inside the bearing housing. A gradual increase in moisture content indicates seal wear. If the grease begins to turn dark, dirty gray, the bearing and seals should be inspected and replaced if necessary. Some discoloration of the grease is normal during the break in period on new sets of seals.

We have selected a water resistant grease of the proper consistency for this application. If you use a substitute grease, be sure it is water resistant and of the same consistency.

IMPELLER

Your jet drive is equipped with a key to protect the unit in the event of a rock jam. This can be reached by removing the water intake, and then the driveshaft nut, similar to a propeller drive. After replacing the key, pull the shaft nut up tight to remove any play between the impeller and shaft. Note the position of the impeller shim washers, and replace them in the same order.

REVERSE GATE MECHANISM

Occasionally check adjustment of the gate shifting linkage. In "forward" the gate should be firmly locked in position. Pull on the gate by hand to verify this. This will prevent wave action from accidentally shifting the gate into reverse as the boat is violently maneuvered

GENERAL

Check all mounting bolts, intake screws, linkage connections, etc., occasionally to be sure they are tight.

SALT WATER USE

Aluminum and stainless steel have been used in the construction of your jet drive. These materials have either been treated or are inherently resistant to corrosion. It is recommended, however, that when not in use the motor be tipped up so that the jet unit is out of the water. When used in salt water more than in fresh water, remove mounting hardware, grease, and reassemble once a year. Failure to do this may result in hardware that is difficult if not impossible to remove at a later date.

GUARANTEE

Due to inflexible government regulation, we do not have a written warranty. We have, however, a good reputation for fairness with our customers which we intend to maintain. If you think you have a warranty situation, regarding material, workmanship, call us before making repairs.

Specialty Manufacturing Company
Outboard Jets
2035 Edison Avenue
San Leandro, CA 94577

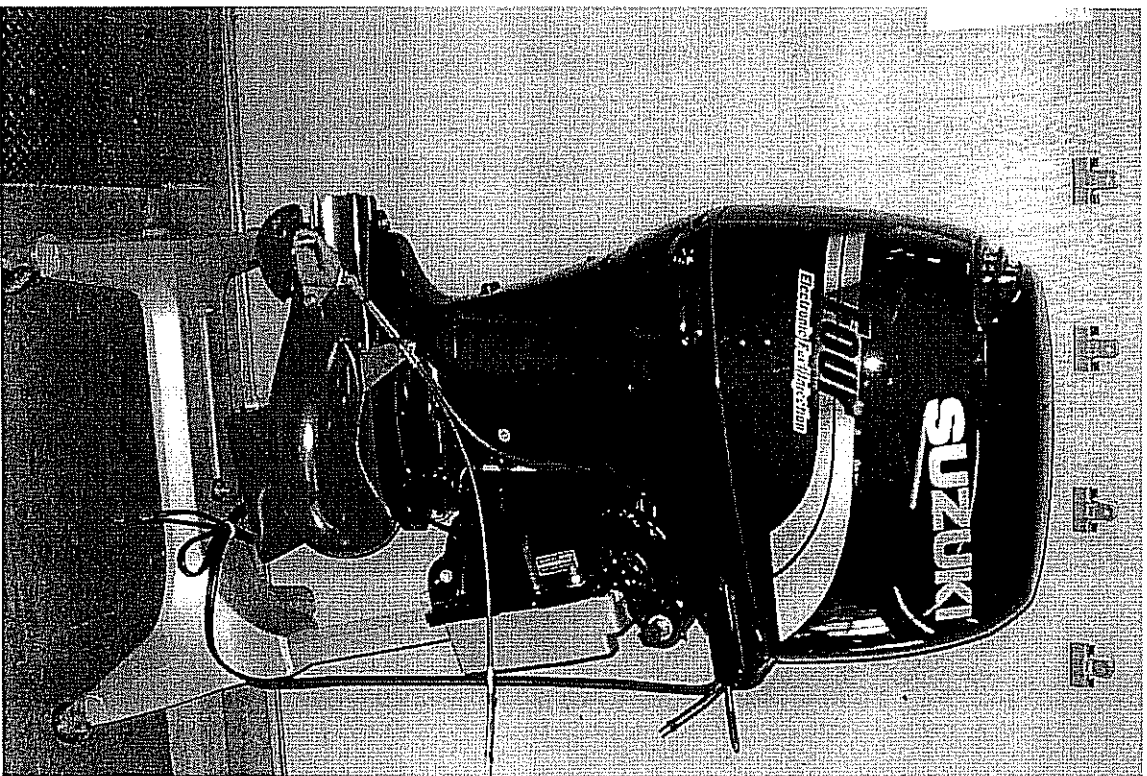
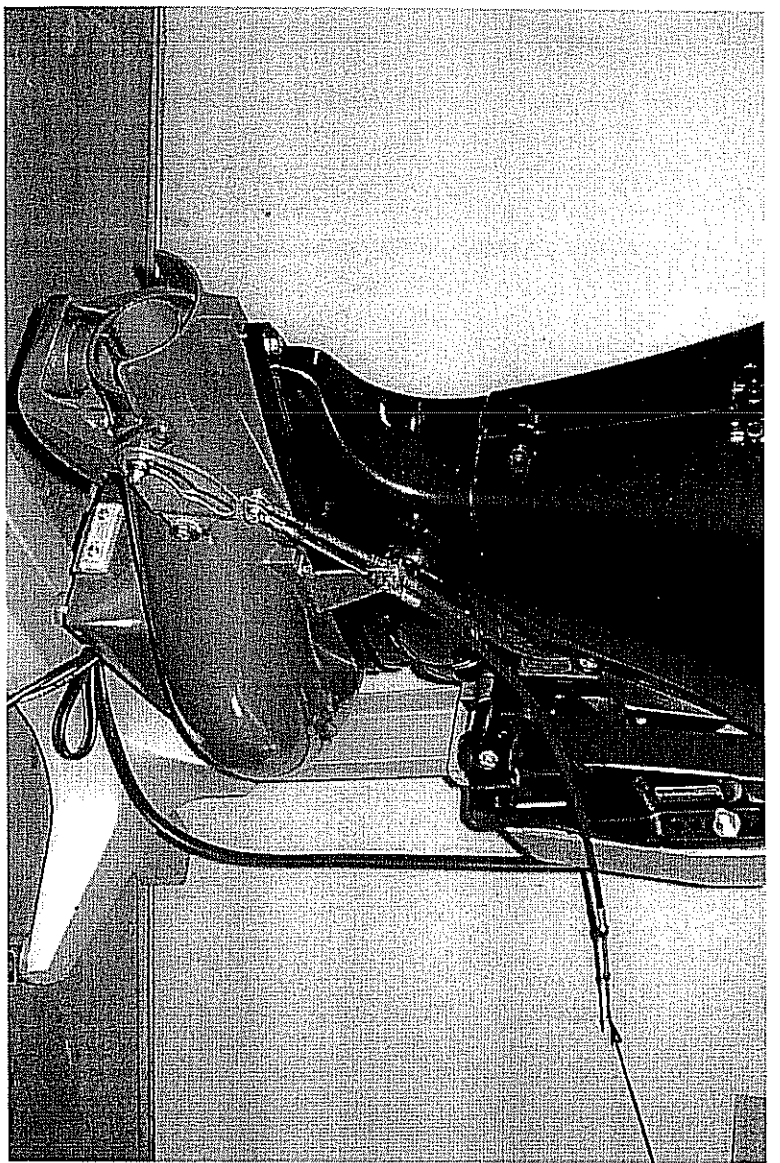
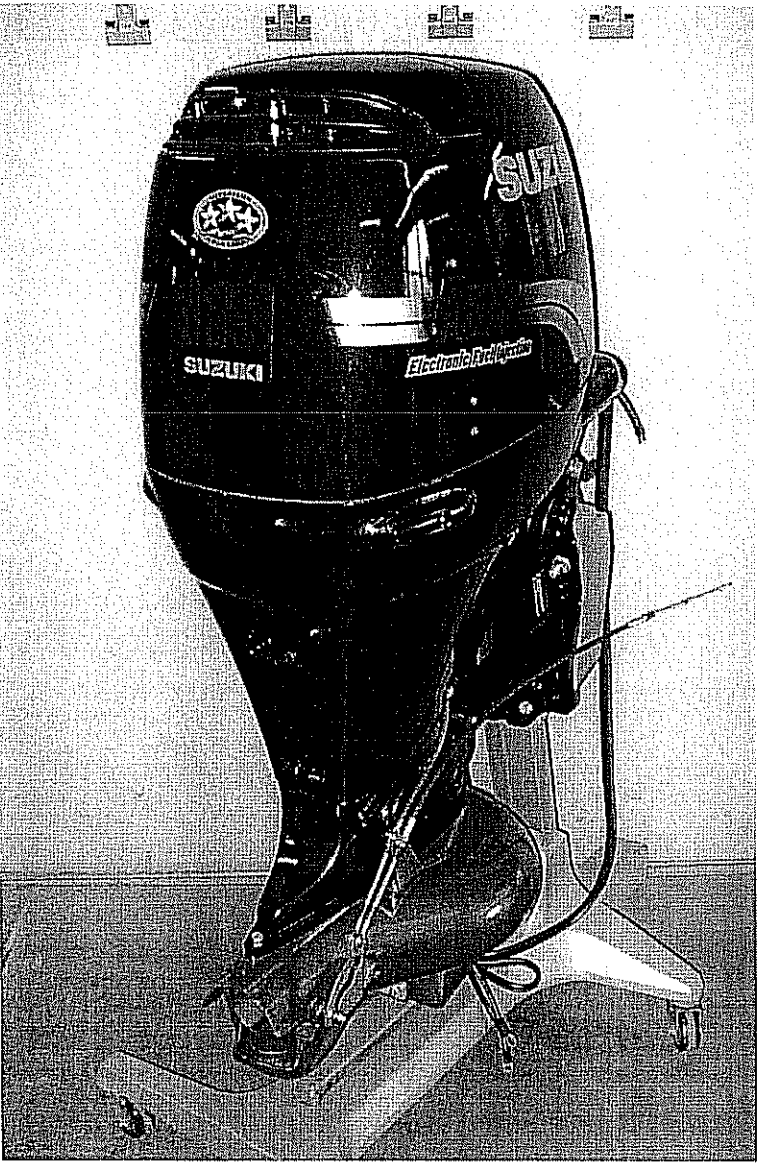

CABLE TO REMOTE CONTROL
LENGTH AS REQUIRED

FIG 1-3

④ - 6 FT NEUTRAL CABLE

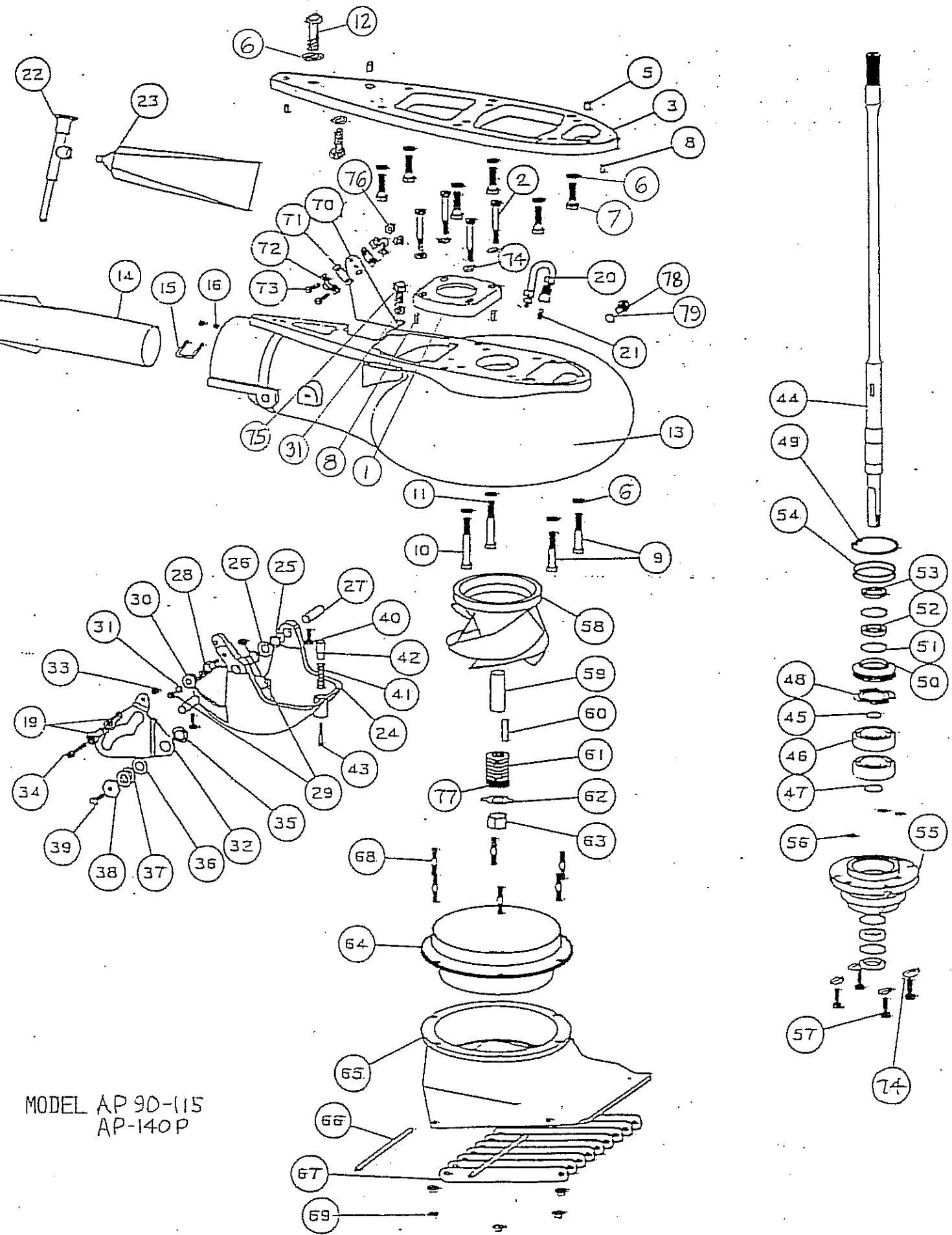

MODEL AP 90-115
AP-140P

701

**MODEL AP-S90-115 AND MODEL AP-S140P (7 5/8 INTAKE) SUZUKI
MODEL AP-E90-115 AND MODEL AP-E140P (7 5/8 INTAKE) JOHNSON / EVINRUDE**

REF NO.	QTY	PART NO.	DESCRIPTION	REF NO.	QTY	PART NO.	DESCRIPTION																																				
1	1	1542	PUMP ADAPTER AP	49	1	513	TRUARC N5002-250ZD																																				
2	4	597.1	BOLT HEX HD 5/16-18 X 1 3/4	50	1	432	UPPER SEAL CARRIER W/SEALS & O RINGS																																				
2	4	603	BOLT HEX HD 5/16-18 X 2 1/2	51	4	517	SPIROLOX RR-150S																																				
3	1	1763	ADAPTER PLATE AP 90/140	52	2	506	SEAL INNER																																				
4	1	1754	NEUTRAL CABLE ASSY SUZUKI	53	2	507	SEAL OUTER 6324-S																																				
	1	1547	NEUTRAL CABLE ASSY EVINRUDE	54	2	527	O RING 568-141 3/32X2 5/16X2 1/2																																				
5	2	HONDA	DOWEL PIN	55	1	393.5	BEARING CARRIER W/SEALS & O RINGS 5/16																																				
6	12	636	WASHER SPRING LOCK M10	56	3	521	O RING 568-011 1/16X5/16X7/16																																				
7	7	592	BOLT HEX HD M10-1.25 X 35MM	57	4	602.1	BOLT HEX HD 5/16-18 X 1 PATCH																																				
8	2	631	DOWEL PIN 3/16 X 1/2	58	1	1738	IMPELLER 7 3/8 STAINLESS V6																																				
9	2	608	BOLT HEX HD 3/8-16 X 2 1/4	59	1	136	SHAFT SLEEVE PLASTIC LARGE																																				
10	1	609	BOLT HEX HD 3/8-16 X 2 3/4	60	1	1706	IMPELLER TEE KEY - 1/2 ROUND																																				
11	1	610	BOLT HEX HD 3/8-16 X 3	61	7	121	SHIM WASHERS																																				
12	1	607	BOLT HEX HD 3/8-16 X 1 1/2	62	1	781	NUT KEEPER LARGE 2 PER BAG																																				
		1541.02	VOLUTE WITH GATE AP	63	1	122.1	SHAFT NUT 3/4-16 BRASS																																				
13	1	1540.02	VOLUTE WITH EXHAUST TUBE AP			1333.02	INTAKE ASSY FLANGED WITH GRILL BAR & LINER																																				
14	1	128	EXHAUST TUBE ASSY LARGE 2 1/2	64	1	1431	LINER FLANGED 7 3/8																																				
15	1	845	CLIP EXHAUST TUBE 1 3/8	65	1	1332.02	INTAKE PAINTED ONLY 7 3/8																																				
16	2	621	NYLOC 10-32	66	2	14	GRILL ROD																																				
19	2	553.2	BALL END 1/4X10-32 CABLE	67	9	117	GRILL BAR LARGE																																				
20	1	975	LUBE HOSE ASSY	68	6	1319	STUD - INTAKE LARGE																																				
21	1	539	ZIRC FITTING 1/4-28	69	6	625	NYLOC 5/16-18																																				
22	1	560	GREASE GUN	70	1	156	BRACKET CABLE SUPPORT																																				
23	1	552	GREASE 10 OZ TUBE NO. 630-AA	71	2	542	SHIM MORSE A035777																																				
24	1	1172.02	REVERSE GATE LARGE	72	2	543	CLAMP CHRYS 154317																																				
25	2	536	NYLINER 1/2 ID X 13/16	73	2	561.1	FL HD SLOTTED 10-24 X 3/4																																				
26	1	1178	SPRING GATE PIVOT 1/2	74	4	640	WASHER SPRING LOCK 5/16																																				
27	2	823	PIN GATE PIVOT 1/2 LARGE	75	2	572	BOLT HEX HD 1/4-20 X 5/8																																				
28	1	1043	SHAFT ROLLER	76	2	619	NYLOC 10-24																																				
29	2	624	NYLOC 1/4-28	77	1	1719	TORSIONAL DAMPER 3/4																																				
30	1	1042	ROLLER ASSY	78	1	1022	BOLT HEX HD 3/8-16 X 1/2																																				
31	3	635	1/4 WASHER AN960C416	79	1	1023	WASHER FIBER 3/8																																				
32	1	1034	SHIFT CAM LARGE	MODEL AP-140P BALANCE OF PARTS SAME AS AP90 - 115																																							
33	1	623	NYLOC 1/4-20																																								
34	1	576	BOLT HEX HD 1/4-20 X 1	<table border="1"> <thead> <tr> <th>REF NO.</th> <th>QTY</th> <th>PART NO.</th> <th>DESCRIPTION</th> </tr> </thead> <tbody> <tr> <td></td> <td></td> <td>1771.02</td> <td>VOLUTE WITH GATE AP-140P</td> </tr> <tr> <td>13</td> <td>1</td> <td>1770.02</td> <td>VOLUTE WITH EXHAUST TUBE AP-140P</td> </tr> <tr> <td>58</td> <td>1</td> <td>1721</td> <td>IMPELLER 7 5/8 STAINLESS V6</td> </tr> <tr> <td></td> <td></td> <td>1603.02</td> <td>INTAKE ASSY FLANGED WITH GRILL BAR & LINER</td> </tr> <tr> <td>64</td> <td>1</td> <td>1605</td> <td>LINER FLANGED 7 5/8</td> </tr> <tr> <td>65</td> <td>1</td> <td>1602.02</td> <td>INTAKE PAINTED ONLY 7 5/8</td> </tr> <tr> <td>66</td> <td>2</td> <td>1667</td> <td>GRILL ROD</td> </tr> <tr> <td>67</td> <td>10</td> <td>1622</td> <td>GRILL BAR EX-LARGE</td> </tr> </tbody> </table>				REF NO.	QTY	PART NO.	DESCRIPTION			1771.02	VOLUTE WITH GATE AP-140P	13	1	1770.02	VOLUTE WITH EXHAUST TUBE AP-140P	58	1	1721	IMPELLER 7 5/8 STAINLESS V6			1603.02	INTAKE ASSY FLANGED WITH GRILL BAR & LINER	64	1	1605	LINER FLANGED 7 5/8	65	1	1602.02	INTAKE PAINTED ONLY 7 5/8	66	2	1667	GRILL ROD	67	10	1622	GRILL BAR EX-LARGE
REF NO.	QTY	PART NO.	DESCRIPTION																																								
		1771.02	VOLUTE WITH GATE AP-140P																																								
13	1	1770.02	VOLUTE WITH EXHAUST TUBE AP-140P																																								
58	1	1721	IMPELLER 7 5/8 STAINLESS V6																																								
		1603.02	INTAKE ASSY FLANGED WITH GRILL BAR & LINER																																								
64	1	1605	LINER FLANGED 7 5/8																																								
65	1	1602.02	INTAKE PAINTED ONLY 7 5/8																																								
66	2	1667	GRILL ROD																																								
67	10	1622	GRILL BAR EX-LARGE																																								
35	1	1037	BUSHING CAM																																								
36	1	1038	WASHER CAM																																								
37	2	1039	SHIM - CAM																																								
38	1	1036	CAM ECCENTRIC DRILLED																																								
39	1	574.1	BOLT HEX HD 1/4-20 X 1 PATCH																																								
40	2	574	BOLT HEX HD 1/4-20 X 3/4 PATCH																																								
41	1	1170	SPRING GATE BUMPER																																								
42	1	1497	GATE BUMPER																																								
43	1	559.2	FIL HD SLOTTED 10-32 X 1 1/4 PATCH																																								
44	1	1758	SHAFT ONLY, AP90-140 22T 30 5/16 LONG																																								
		1759.1	SHAFT ASSY COMPLETE, AP90-140 22T 5/16																																								
	1	1761	SHAFT ONLY, AP90-140X 22T 35 5/16 LONG																																								
		1762.1	SHAFT ASSY COMPLETE, AP90-140X 22T 5/16																																								
45	1	41	SHAFT BEARING THRUST RING																																								
46	2	502	BEARING 7305B-UA																																								
47	1	511	TRUARC 5100-98																																								
48	1	404	BACKUP WASHER																																								

TILLER STEERING CABLE 1717 SEE PAGE 26.3

BEARING, SEAL, SNAP & "O" RING KIT
2 BRG 462.2

NEUTRAL CABLE NEEDED FOR REMOTE CONTROL
SUZUKI 1754 SEE PG. 26.4

JOHNSON / EVINRUDE 1547 SEE PG. 26

SIZE	TORQUE
1/4-20 (M6)	8-9 FT-LBS
5/16-18 (M8)	12 FT-LBS
3/8-16 (M10)	22 FT-LBS

LARGE SERIES

NEUTRAL CABLE ASSEMBLY
 EVINRUDE MODELS
 AP-E, U4-4

1547

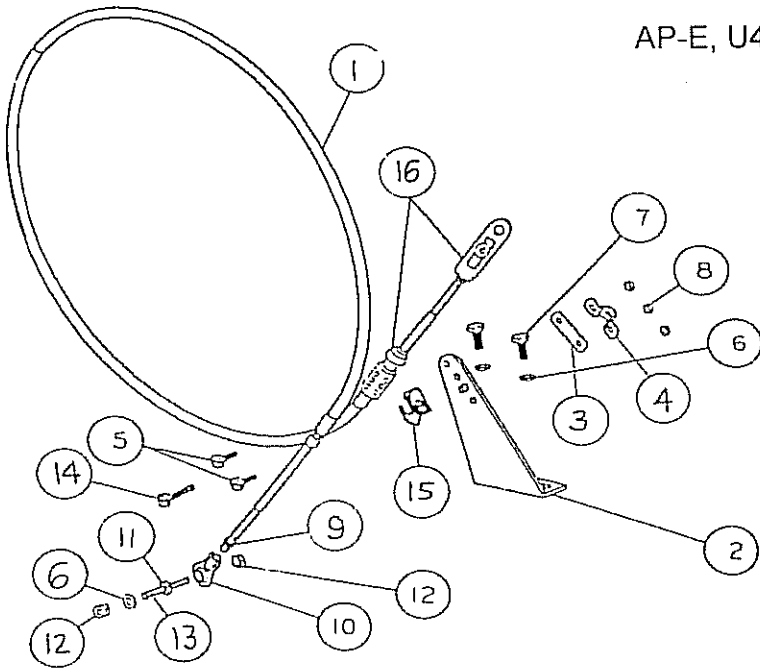

REF	QTY	PART NO.	DESCRIPTION
1	1	547.2	CABLE 5 FT MOR 33C SUPREME
2	1	1499	BRACKET CABLE SUPPORT
3	1	542	SHIM MORSE AO35777
4	1	543	CLAMP CHRYS 154317
5	2	562	PAN HD PHILLIPS 10-32 X 1/2
6	3	635	1/4 WASHER AN960C416
7	2	572	BOLT HEX HD 1/4-20 X 5/8
8	3	621	NYLOC 10-32
9	2	621.1	NUT HEX 10-32
10	1	553.2	BALL END 1/4X10-32 CABLE
11	1	62	NUT HEX JAM 1/4-28
12	2	624	NYLOC 1/4-28
13	1	1199	PIVOT - CABLE END
14	1	562.1	PAN HD PHILLIPS 10-32 X 5/8
15	1	546	CLIP OMC 305736
16	1	1564	OMC CABLE ADAPTER 301729

LARGE SERIES

TILLER CABLE ASSEMBLY
SUZUKI MODEL AP-S70
1717

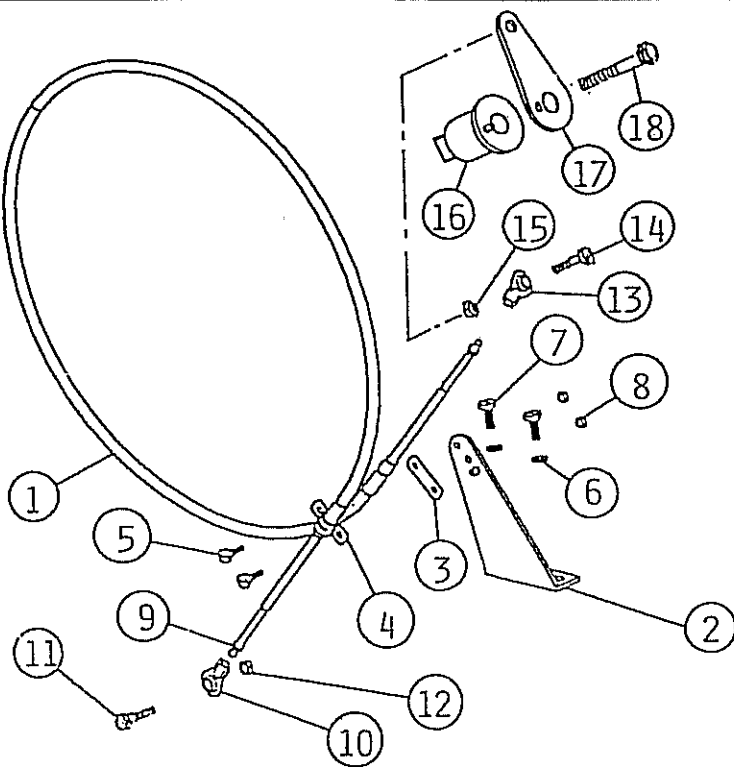

REF	QTY	PART NO.	DESCRIPTION
1	1	547.1	CABLE 4 1/2 FT MOR 33C SUPREME
2	1	156	BRACKET CABLE SUPPORT
3	2	542	SHIM MORSE A035777
4	2	543	CLAMP CHRYS 154317
5	2	561	FIL HD SLOTTED 10-24 X 5/8
6	2	635	1/4 WASHER AN960C416
7	4	572	BOLT HEX HD 1/4-20 X 5/8
8	4	619	NYLOC 10-24
9	2	621.1	HEX NUT 10-32 JAM
10	1	553.2	BALL END 1/4 X 10-32 CABLE
11	1	573	BOLT HEX HD 1/4-20 X 3/4
12	1	623	NYLOCK 1/4-20
13	1	553.1	BALL END #10 X 10-32 CABLE
14	1	558.4	PAN HD PHILLIPS 10-32 X 3/4
15	1	621	NYLOC 10-32
16	1	1594	LEVER MOUNT
17	1	1591	SHIFT LEVER
18	1	591.1	BOLT HEX HD M8 X 1.25 X 60MM

LARGE SERIES

NEUTRAL SWITCH CABLE ASSEMBLY
 MODEL AV, AP90-115, AP140P
 1754

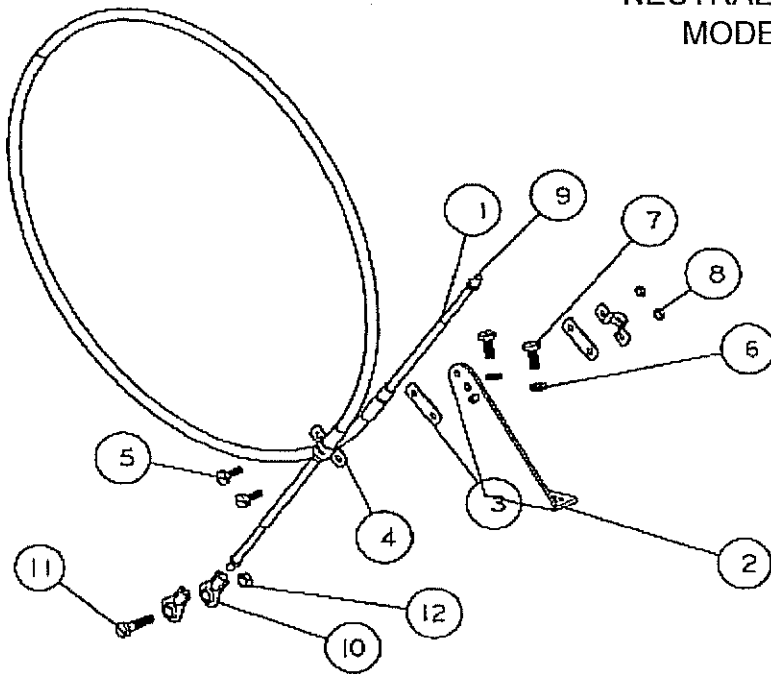

REF	QTY	PART NO.	DESCRIPTION
1	1	556	CABLE 6 FT MOR 33C SUPREME
2	1	156	BRACKET CABLE SUPPORT
3	2	542	SHIM MORSE AO35777
4	2	543	CLAMP CHRYS 154317
5	2	561.1	FIL HD SLOTTED 10-24 X 3/4
6	2	635	1/4 WASHER AN960C416
7	2	572	BOLT HEX HD 1/4-20 X 5/8
8	2	619	NYLOC 10-24
9	2	621.1	HEX NUT 10-32 JAM
10	2	553.2	BALL END 1/4 X 10-32 CABLE
11	1	585	BOLT HEX HD 1/4-20 X 1 1/4
12	1	623	NYLOC 1/4-20