

MODEL AY HONDA SERIES 150 HP  
ASSEMBLY INSTRUCTIONS  
IN-LINE 4 CYLINDER, 4 STROKE 144 CU. IN.

1. Place the engine on the transom of your boat so that it is mounted vertically, in the normal fashion. Remove the bolts holding the gearbox to the exhaust housing and remove the gearbox assembly.
2. Remove the water pump assembly from the propeller drive, including the lower stainless steel plate, dowel pins, and impeller drive key.
3. Install the jet driveshaft assembly into the main housing locking it in place with the four 5/16-18 x 1 bolts with lock washers. Use grease on the threads. Tighten to 15 Ft-Lbs.
4. Install the water pump assembly on top of the stainless steel plate. Be sure also, to install the water pump impeller drive key removed from the propeller drive. Lock in place using four Honda bolts and lock washers. Grease the threads. Tighten to 8 Ft-Lbs. Attach the cable anchor bracket to the main housing. Slide all the way forward and lock the bolts.
5. The large 3/4" adapter plate is attached to the exhaust housing to hold the jet drive. A 5/16 x 1 3/4" plastic shift rod guide in the front of the plate guides the disconnected shift rod. Two Honda dowels locate the plate, five M10 x 35MM bolts with lock washers secure it. Grease the bolt threads and the end of the pin where it slides in the shift rod. Tighten to 22 Ft-Lbs.
6. Next, attach the jet drive to the motor. Two 3/16 x 1/2 dowel pins center the jet drive on the adapter plate. Two 3/8-16, two M10 bolts from below, and one 3/8-16 x 1 1/2" bolt from above rear, with lock washers are used.

Grease the bolt threads, driveshaft spline generously, and rubber water tube pilot and guide the jet into place. Tighten to 22 Ft-Lbs.

7. Next, install the impeller. Grease the shaft threads, key and impeller bore. Place the plastic sleeve inside the impeller, hold the key in the nose of the impeller with your forefinger and slide onto the driveshaft. Install the seven shim washers, rubber washer and cup, and nut retainer on the shaft, up against the impeller, and bring the nut up snug by hand.

Then bump the nut up snug with a wrench. If the ears of the retainer do not line up with the flats on the nut, spin the nut off, turn the retainer over and tighten the nut again. In one of these two positions you will have alignment and can fold the ears up against the nut to retain it. The flat in the retainer is angled to the ears to allow this.

When, after use in sand and gravel, the blade clearance becomes more than about 1/32" between the impeller edge and the water intake liner, one or more of the shim washers can be transferred from the bottom stack to the top of the impeller, which moves the impeller down into the tapered casing to reduce the clearance.

**Shims should not be used above the impeller on new installations where no wear has occurred unless the blade clearance exceeds 1/32 inch. Insufficient blade clearance will do more harm than good from any performance gains it might provide.**

8. Place the intake casing in position with the lower end at the rear and tighten the six nuts. No lock washers are used. Grease the threads.
9. Attach the shift and neutral cables to the cable anchor bracket. See 1815 neutral cable sheet.

MODEL AY HONDA SERIES 150 HP  
ASSEMBLY INSTRUCTIONS  
IN-LINE 4 CYLINDER, 4 STROKE 144 CU. IN.

10. With the shift handle in forward and the reverse gate in forward, **with the cam roller at the end of the slot,** adjust the cable and/or cable anchor position to this condition. **Shift to reverse and back to forward. The roller should be at the end of the cam slot such that the gate cannot be forcibly rotated toward reverse. Pull on the gate by hand to verify this.**

If this forward lock condition is not met, readjust the cable positions.

11. **When converting to jet drive, your motor will have to be raised to height shown in diagram below, using a straight edge under the boat.** Test run the boat and then raise or lower the motor 5/16 inch at a time to obtain the best results.

The motor has four sets of upper mounting holes. You will use one set to begin with. Mark pencil lines on the boat transom through the other sets. Then if you wish to go up or down 3/8 inch, you can drill one alternate set of holes 3/8 inch up or down from the pencil marks. By alternating between these two sets of transom holes and the three sets of motor holes, the motor can be moved in 3/8 inch increments over almost one inch. The transom height should be about 26" measured vertically from the boat bottom.

**If you raise it too much it will suck air and cavitate, either on start up or when banking on turns.** When cavitating, the motor overspeeds in spurts and shakes considerably in the motor mount. **This is not a normal condition and should be avoided by proper adjustment of motor height on each individual boat.** If you lower it too much you will have excessive drag, therefore mount the motor as high as possible without allowing cavitation.

### **SETTING MOTOR HEIGHT**

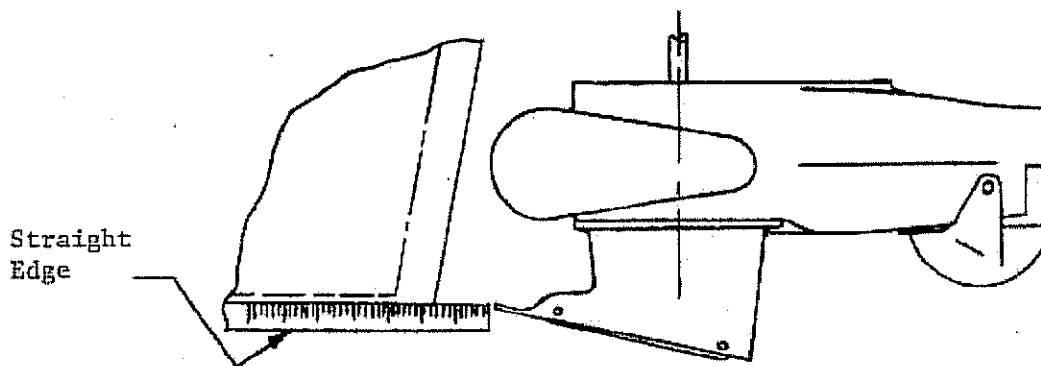

### **CAUTION**

**When starting the engine for the first time, watch to see that the cooling water comes out of the small hole at the left side of the engine just below the powerhead.** This is to check your assembly of the cooling water pump and its connections.

MODEL AY HONDA SERIES 150 HP  
ASSEMBLY INSTRUCTIONS  
IN-LINE 4 CYLINDER, 4 STROKE 144 CU. IN.

**MAINTENANCE AND LUBRICATION**

See last page.

**CAUTION**

**V4 and V6 jet drives**

It is important on high HP installations to mount the motor at the correct height and to use the power tilt properly.

Power tilt is convenient for drifting and when operating at low throttle in very shallow areas. When under power however, the engine should not be tilted out in an effort to gain speed as is done with propellers.

The engine driveshaft should be vertical when planing or tilted toward the boat in order to provide a scooping angle on the water intake grill. **Tilting the motor out beyond a vertical position reduces the scoop angle and can cause impeller slippage and cavitation burns on the impeller blades.**

When running in a bay, lake or wide river in windy conditions, particularly when running with the wind, the jet can suck in air when jumping across the wave crests. This will result in overspeeding and causes severe strain on the driveshaft when the engine is suddenly brought back to normal speed as the impeller once again grabs solid water.

If your boat is used frequently under these conditions, the engine height should be set lower than normal to minimize overspeeding. Running at reduced throttle will help when winds are strong. You can also experiment with a plate extending from the hull bottom to the top of the leading edge of the water intake as shown in paragraph 7 of the owner's manual. This tends to reduce air intake as well as to reduce spray.

**A water intake fin kit, part #1186 is now available.** The purpose of these fins is to ram more water into the intake and to shield the forward sides of the intake from the entrance of air. There is a noticeable reduction of engine overspeeding when running with the wind on a heavy chop. To a lesser degree, the fins provide some rudder effect when operating at a low speeds. This is not a cure all for cavitation and it is still necessary to set the engine height and angle properly and to minimize obstructions or imperfections in the hull ahead of the intake.

GOOD BOATING AND HAVE FUN!

Specialty Manufacturing Company  
Outboard Jets  
2035 Edison Avenue  
San Leandro, CA 94577

# MAINTENANCE AND LUBRICATION OUTBOARD JET DRIVE

## BEARING LUBRICATION

A grease gun and tube of grease is supplied with your jet drive. We recommend greasing the bearing every 10 hours. Make greasing a part of your cleanup after the days use. Pump in just enough grease to fill the lube hose. Then reconnect the lube hose coupling to the zerk grease fitting.

Every 30-40 hours, pump in extra grease so as to purge any moisture. The texture of the grease coming out gives an indication of conditions inside the bearing housing. A gradual increase in moisture content indicates seal wear. If the grease begins to turn dark, dirty gray, the bearing and seals should be inspected and replaced if necessary. Some discoloration of the grease is normal during the break in period on new sets of seals.

We have selected a water resistant grease of the proper consistency for this application. If you use a substitute grease, be sure it is water resistant and of the same consistency.

## IMPELLER

Your jet drive is equipped with a key to protect the unit in the event of a rock jam. This can be reached by removing the water intake, and then the driveshaft nut, similar to a propeller drive. After replacing the key, pull the shaft nut up tight to remove any play between the impeller and shaft. Note the position of the impeller shim washers, and replace them in the same order.

## REVERSE GATE MECHANISM

Occasionally check adjustment of the gate shifting linkage. In "forward" the gate should be firmly locked in position. Pull on the gate by hand to verify this. This will prevent wave action from accidentally shifting the gate into reverse as the boat is violently maneuvered

## GENERAL

Check all mounting bolts, intake screws, linkage connections, etc., occasionally to be sure they are tight.

## SALT WATER USE

Aluminum and stainless steel have been used in the construction of your jet drive. These materials have either been treated or are inherently resistant to corrosion. It is recommended, however, that when not in use the motor be tipped up so that the jet unit is out of the water. When used in salt water more than in fresh water, remove mounting hardware, grease, and reassemble once a year. Failure to do this may result in hardware that is difficult if not impossible to remove at a later date.

## GUARANTEE

Due to inflexible government regulation, we do not have a written warranty. We have, however, a good reputation for fairness with our customers which we intend to maintain. If you think you have a warranty situation, regarding material, workmanship, call us before making repairs.

Specialty Manufacturing Company  
Outboard Jets  
2035 Edison Avenue  
San Leandro, CA 94577

LARGE SERIES

NEUTRAL CABLE ASSEMBLY  
MODEL AW YAMAHA, AY HONDA  
1815

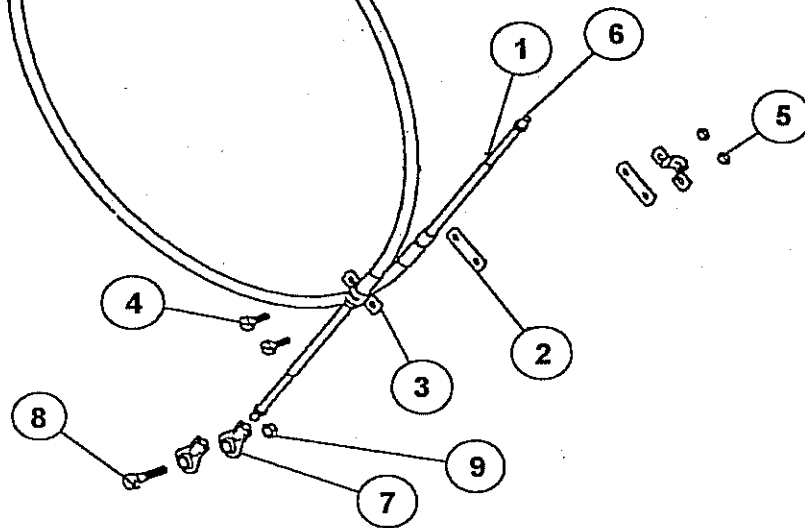

REF	QTY	PART NO.	DESCRIPTION
1	1	556	CABLE 6 FT MOR 33C SUPREME
2	2	542	SHIM MORSE AO35777
3	2	543	CLAMP CHRYS 154317
4	2	561.1	FIL HD SLOTTED 10-24 X 3/4
5	2	619	NYLOC 10-24
6	2	621.1	HEX NUT 10-32 JAM
7	2	553.2	BALL END 1/4 X 10-32 CABLE
8	1	585	BOLT HEX HD 1/4-20 X 1 1/4
9	1	623	NYLOC 1/4-20

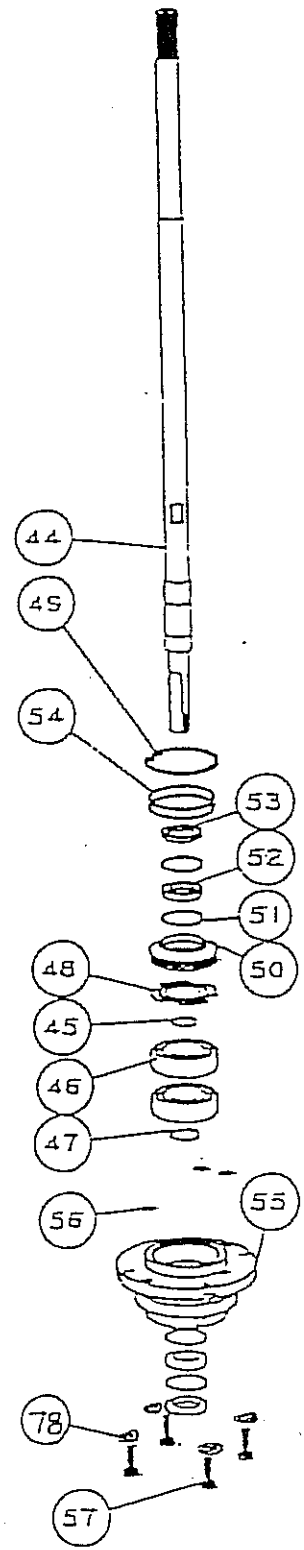
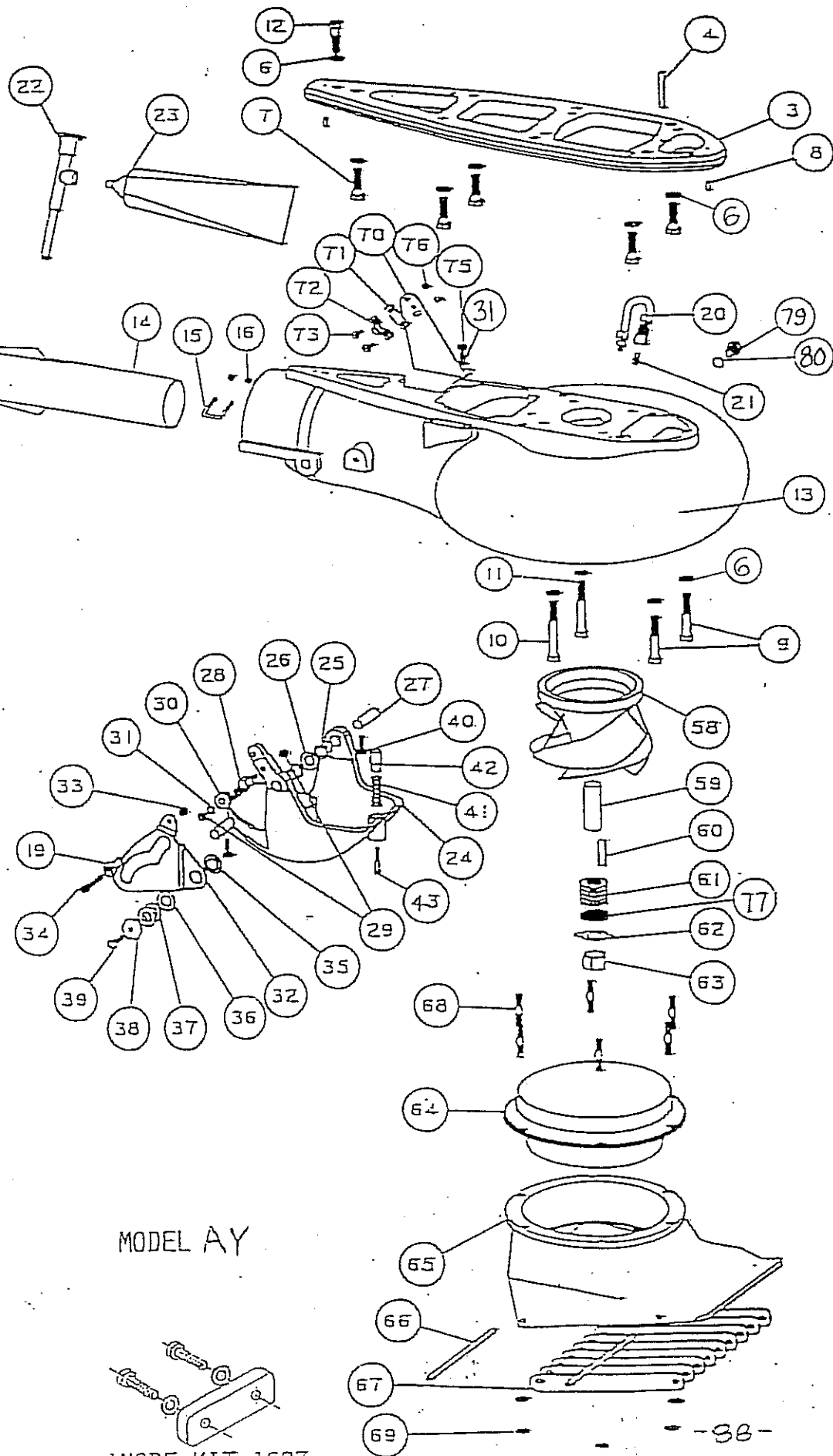

MODEL AY

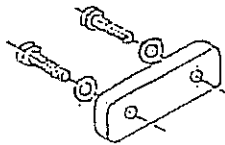
  
 ANODE KIT 1693

**MODEL AY HONDA 150HP  
IN-LINE 4 CYL. 4 STROKE 144 CU. IN.**

REF	QTY	PART NO.	DESCRIPTION	REF	QTY	PART NO.	DESCRIPTION
3	1	1816	ADAPTER PLATE AY	54	2	527	O RING 568-141 3/32X2 5/16X2 1/2
4	1	1661 REV A	SHIFT ROD GUIDE AY	55	1	393.5	BEARING CARRIER W/SEALS & O RINGS 5/16
6	10	636	WASHER SPRING LOCK M10	56	3	521	O RING 568-011 1/16X5/16X7/16
7	5	592	BOLT HEX HD M10-1.25 X 35MM	57	4	602.1	BOLT HEX HD 5/16-18 X 1 PATCH
8	2	631	DOWEL PIN 3/16 X 1/2	58	1	1839	IMPELLER 7 3/16 V6 STAINLESS
9	2	608	BOLT HEX HD 3/8-16 X 2 1/4	59	1	136	SHAFT SLEEVE PLASTIC LARGE
10	1	592.5	BOLT HEX HD M10-1.25 X 100MM	60	1	1706	IMPELLER TEE KEY - 1/2 ROUND
11	1	592.4	BOLT HEX HD M10-1.25 X 90MM	61	8	121	SHIM WASHERS
12	1	607	BOLT HEX HD 3/8-16 X 1 1/2	62	1	781	NUTKEEPER (2 PER BAG)
		1820	VOLUTE WITH GATE AY	63	1	122.1	SHAFT NUT 3/4-16 BRASS
13	1	1819	VOLUTE WITH EXHAUST TUBE AY			1840.05	INTAKE ASSY FLANGED WITH GRILL BAR & LINER
14	1	128	EXHAUST TUBE ASSY LARGE 2 1/2	64	1	1831	LINER 7 3/16 FLANGED
15	1	845	CLIP EXHAUST TUBE 1 3/8	65	1	1332	INTAKE PAINTED ONLY
16	2	621	NYLOC 10-32	66	2	14	GRILL ROD
19	2	553.2	BALL END 1/4X10-32 CABLE	67	9	117	GRILL BAR LARGE
20	1	975	LUBE HOSE ASSY	68	6	1319	STUD - INTAKE LARGE
21	1	539	ZIRC FITTING 1/4-28	69	6	625	NYLOC 5/16-18
22	1	550	GREASE GUN	70	1	156	BRACKET CABLE SUPPORT
23	1	552	GREASE 10 OZ TUBE NO. 630-AA	71	2	542	SHIM MORSE AO35777
24	1	1172	REVERSE GATE LARGE	72	2	543	CLAMP CHRYS 154317
25	2	536	NYLINER 1/2 ID X 13/16	73	2	561.1	FIL HD SLOTTED 10-24 X 3/4
26	1	1178	SPRING GATE PIVOT 1/2	75	2	572	BOLT HEX HD 1/4-20 X 5/8
27	2	823	PIN GATE PIVOT 1/2 LARGE	76	2	619	NYLOC 10-24
28	1	1043	SHAFT ROLLER	77	1	1719	TORSIONAL DAMPER 3/4
29	2	624	NYLOC 1/4-28	78	4	640	WASHER SPRING LOCK 5/16
30	1	1042	ROLLER ASSY	79	1	1022	BOLT HEX HD 3/8-16 X 1/2
31	3	635	1/4 WASHER AN960C416	80	1	1023	WASHER FIBER 3/8
32	1	1034	SHIFT CAM LARGE				
33	1	623	NYLOC 1/4-20				
34	1	576	BOLT HEX HD 1/4-20 X 1				
35	1	1037	BUSHING CAM				
36	1	1038	WASHER CAM				
37	2	1039	SHIM - CAM				
38	1	1036	CAM ECCENTRIC DRILLED				
39	1	574.1	BOLT HEX HD 1/4-20 X 1 PATCH				
40	2	574	BOLT HEX HD 1/4-20 X 3/4 PATCH				
41	1	1170	SPRING GATE BUMPER				
42	1	1497	GATE BUMPER				
43	1	559.2	FIL HD SLOTTED 10-32 X 1 1/4 PATCH				
44	1	1822	SHAFT ONLY, AY 19T 29-3/4 LG				
		1823.1	SHAFT ASSY COMPLETE, AY 19T-5/16				
45	1	141	SHAFT BEARING THRUST RING				
46	2	502	BEARING 7305B-UA				
47	1	511	TRUARC 5100-98				
48	1	404	BACKUP WASHER				
49	1	513	TRUARC N5002-250ZD				
50	1	432	UPPER SEAL CARRIER W/SEALS & O RINGS				
51	4	517	SPIROLOX RR-150S				
52	2	506	SEAL INNER				
53	2	507	SEAL OUTER 6324-S				

SIZE	TORQUE
1/4-20 (M6)	8-9 FT-LBS
5/16-18 (M8)	12 FT-LBS
3/8-16 (M10)	22 FT-LBS

BEARING, SEAL, SNAP & "O" RING KIT  
2 BRG 462.2

NEUTRAL CABLE ASSY 1815, pg. 26.6 – NOT  
NEEDED WITH TILLER STEERING

SHIFT CABLE ASSY 1829 SEE PAGE 25.2

MEDIUM SERIES

SHIFT CABLE ASSEMBLY HONDA TILLER  
 STEERING HANDLE - STARTING 2004  
 SHORT 15" MOTOR 1828  
 LONG 20" MOTOR 1829

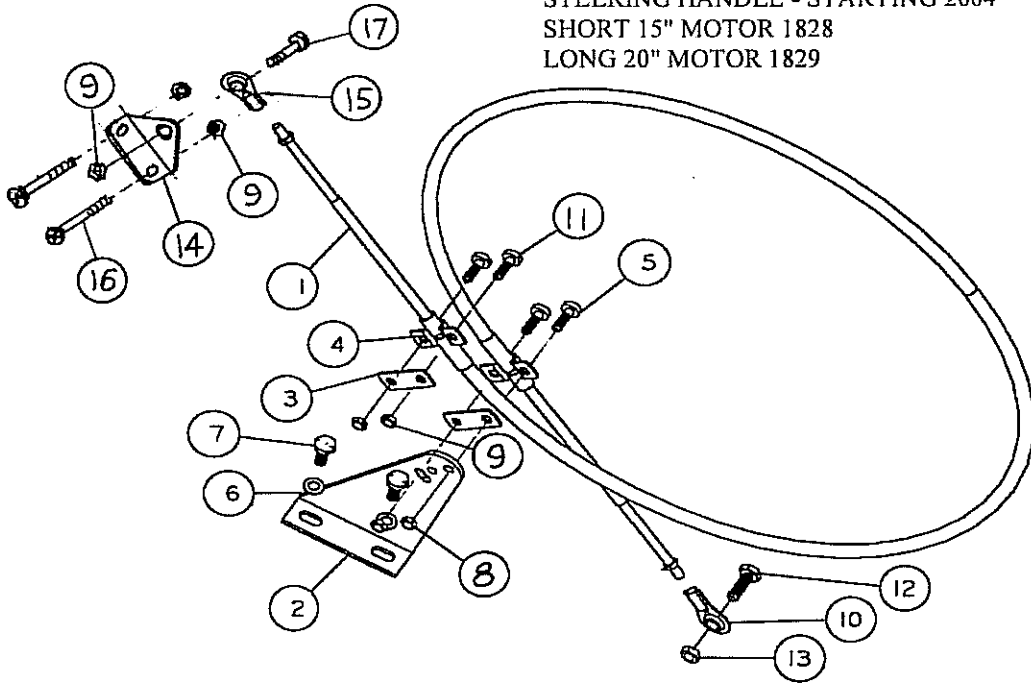

REF	QTY	PART NO.	DESCRIPTION
1	1	547	CABLE 4 FT MOR 33C SUPREME SHORT
1	1	547.1	CABLE 4 1/2 FT MOR 33C SUPREME LONG
2	1	156	BRACKET CABLE SUPPORT
3	2	542	SHIM MORSE AO35777
4	2	543	CLAMP CHRYS 154317
5	2	561	FIL HD SLOTTED 10-24 X 5/8
6	2	635	1/4 WASHER AN960C416
7	2	572	BOLT HEX HD 1/4-20 X 5/8
8	2	619	NYLOC 10-24
9	5	621	NYLOC 10-32
10	1	553.2	BALL END 1/4 X 10-32 CABLE
11	2	562	PAN HD SLOTTED 10-32 X 1/2
12	1	573	BOLT HEX HD 1/4-20 X 3/4
13	1	623	NYLOC 1/4-20
14	1	1824	SHIFT LEVER AI HONDA LONG 04
15	1	553.1	BALL END #10X10-32 CABLE
16	2	558.1	PAN HD PHILLIPS 10-32 X 1 1/2
17	1	558.4	PAN HD PHILLIPS 10-32 X 3/4