

## MODEL J SERIES

### ASSEMBLY INSTRUCTIONS

For Chrysler/Force Motors - 30-35 HP 34.1 cu. in., 1967 - 1984  
40-50 HP 42.2-50.1 cu. in., 1967 to present

1. Place the engine on the transom of your boat so that it is mounted vertically, in the normal fashion. Remove the exhaust housing covers, surrounding the cooling water outlet, to allow access to the shift rod coupling.
2. Loosen the jam nut on the hex shift rod coupling. Remove the 4 bolts holding the gearbox. Then unwind the hex shift rod coupling and remove the gearbox.
3. Remove the entire water pump assembly from the gearbox. Good luck on these 3 flat head screws - they're tight! One way is to use a flat punch and hammer and drive on one end of the screwdriver slot, in a counterclockwise direction, until it can be turned with the screwdriver.
4. Install the jet driveshaft assembly in the spiral pump housing using 2 - 1/4-20 x 3/4 hex head bolts and lockwashers.
5. Install the water pump assembly, locking the screws firmly. Be sure the pump is in good condition and that the rubber impeller fingers are all pointing backwards when turning the driveshaft in a clockwise direction looking down from above. Don't forget impeller drive pin.
6. The shift rod mechanism is not used to shift the jet reverse gate, and must be locked in a dormant position to prevent its getting in the way of the throttle mechanism movement. A threaded 1/4 inch rod is provided for this purpose. Install a 1/16 x 5/8 cotter pin in the hole nearest the end of the rod. Push the rod up into the vacant shift rod hole and engage the hex coupling. Grip the lower end of the rod with pliers and tightly jam the hex coupling down against the end of the threads. Slide the rod up as far as it will go and install a second 1/16 x 5/8 cotter pin on top to prevent the rod from moving up and down. Now turn the entire rod end hex coupling into position on the upper gearshift rod until the shift arm stop is below the throttle idle cam, out of the way. Lock the coupling jam nut.
7. The shift arm can no longer activate the starter limit switch, so attach the 2 switch leads together on one terminal to jumper the switch. It is now possible to start the motor at advanced throttle positions, so be sure the remote control box is in neutral when starting the motor.
8. Tip the engine up toward the horizontal and install the jet pump housing with driveshaft and water pump. Grease the driveshaft spline generously and a little on the cooling water tube helps engagement. Be sure, as you guide the housing into position, that the cooling water tube engages the water pump. Install the 4 - 3/8-16 hex bolts and lockwashers and lock tightly.
9. Next, install the impeller. Grease the shaft threads, key and impeller bore. Place the plastic sleeve inside the impeller, hold the key in the nose of the impeller with your forefinger and slide onto the driveshaft. Install the nine shim washers and nut retainer on the shaft, up against the impeller, and bring the nut up snug by hand. Be careful that the retainer does not fall into the thread groove and jam the nut.

MODEL J SERIES

10. Place the water intake in position and secure with 2 bolts. Observe the clearance between the impeller blade edge and the intake liner. Then remove the intake.

When, after use in sand and gravel, the blade clearance becomes more than about  $1/32$ " between the impeller edge and the water intake liner, one or more of the stainless shim washers can be transferred from the bottom stack to the top of the impeller, which moves the impeller down into the tapered casing to reduce the clearance.

Shims should not be used above the impeller on new installations, where no wear has occurred, unless the blade clearance exceeds  $1/32$ ". Insufficient blade clearance will do more harm than good from any performance gains it might provide.

When the impeller clearance is satisfactory, bump the nut up snug with a wrench. If the ears of the retainer do not line up with the flats on the nut, spin the nut off, turn the retainer over and tighten the nut again. In one of these two positions you will have alignment and can fold the ears up against the nut to retain it. The flat in the retainer is angled to the ears to allow this.

11. Place the intake casing in position with the lower end at the rear and tighten the six  $1/4-20 \times 3/4$  hex head bolts. No lockwashers are used. Grease the threads. See diagram page 3.
12. Attach the shift cable and cable anchor bracket to the jet drive, using two  $1/4-20 \times 5/8$  bolts and flat washers. Attach the cable.

Using a light finger pressure on the gate, move the gate toward reverse until the cam roller is nested in the neutral notch of the cam.

Adjust the shift cable end and the cable anchor bracket on the jet drive such that the roller is in the neutral notch when the shift handle is in neutral. Tighten hardware.

Shift to forward. The roller should be well onto the flat section of the cam such that the gate cannot be forcibly rotated toward reverse. Pull on the gate by hand to verify this.

If this forward lock condition is not met, readjust the cable positions, giving less importance to the roller position in neutral.

13. When converting to jet drive, your motor will have to be raised to height shown in diagram on page 3, using a straight edge under the boat. Test run the boat and then raise or lower the motor  $5/16$  inch at a time to obtain the best results.

If you raise it too much it will suck air and cavitate, either on start up or when banking on turns. When cavitating, the motor over speeds in spurts and shakes considerably in the motor mount. This is not a normal condition and should be avoided by proper adjustment of motor height on each individual boat. If you lower it too much you will have excessive drag, therefore mount the motor as high as possible without allowing cavitation.

MODEL J SERIES

CAUTION

When starting the engine for the first time, watch to see that cooling water comes out of the small hole at the rear side of engine just below the powerhead. This is to check your assembly of the cooling water pump and its connections.

MAINTENANCE AND LUBRICATION

See separate sheet

GOOD BOATING AND HAVE FUN!

PROPER ENGINE HEIGHT

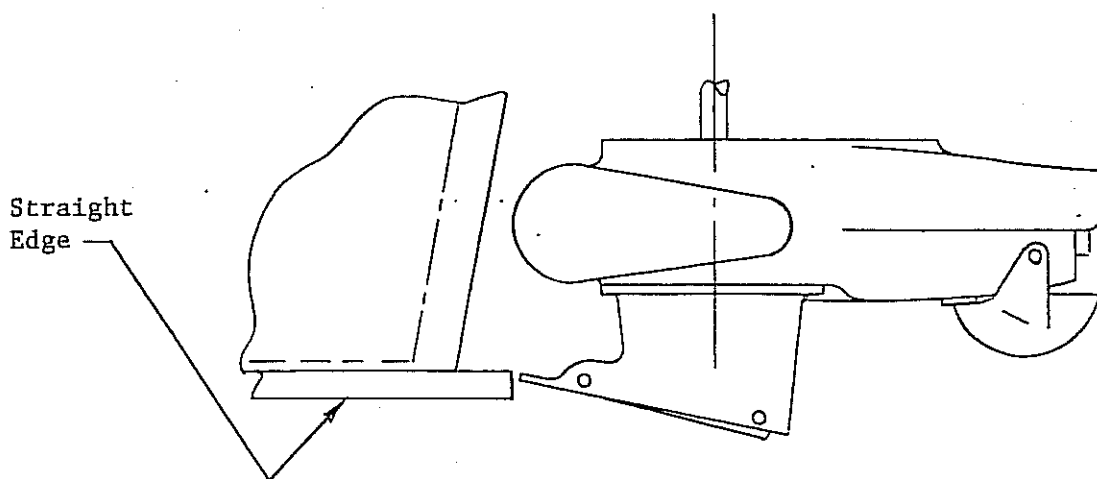

Specialty Manufacturing Company  
OUTBOARD JETS  
2035 Edison Avenue  
San Leandro, CA 94577

# MAINTENANCE AND LUBRICATION OUTBOARD JET DRIVE

## BEARING LUBRICATION

A grease gun and tube of grease is supplied with your jet drive. We recommend greasing the bearing every 10 hours. Make greasing a part of your cleanup after the days use. Pump in just enough grease to fill the lube hose. Then reconnect the lube hose coupling to the zerk grease fitting.

Every 30-40 hours, pump in extra grease so as to purge any moisture. The texture of the grease coming out gives an indication of conditions inside the bearing housing. A gradual increase in moisture content indicates seal wear. If the grease begins to turn dark, dirty gray, the bearing and seals should be inspected and replaced if necessary. Some discoloration of the grease is normal during the break in period on new sets of seals.

We have selected a water resistant grease of the proper consistency for this application. If you use a substitute grease, be sure it is water resistant and of the same consistency.

## IMPELLER

Your jet drive is equipped with a key to protect the unit in the event of a rock jam. This can be reached by removing the water intake, and then the driveshaft nut, similar to a propeller drive. After replacing the key, pull the shaft nut up tight to remove any play between the impeller and shaft. Note the position of the impeller shim washers, and replace them in the same order.

## REVERSE GATE MECHANISM

Occasionally check adjustment of the gate shifting linkage. In "forward" the gate should be firmly locked in position. Pull on the gate by hand to verify this. This will prevent wave action from accidentally shifting the gate into reverse as the boat is violently maneuvered

## GENERAL

Check all mounting bolts, intake screws, linkage connections, etc., occasionally to be sure they are tight.

## SALT WATER USE

Aluminum and stainless steel have been used in the construction of your jet drive. These materials have either been treated or are inherently resistant to corrosion. It is recommended, however, that when not in use the motor be tipped up so that the jet unit is out of the water. When used in salt water more than in fresh water, remove mounting hardware, grease, and reassemble once a year. Failure to do this may result in hardware that is difficult if not impossible to remove at a later date.

## GUARANTEE

Due to inflexible government regulation, we do not have a written warranty. We have, however, a good reputation for fairness with our customers which we intend to maintain. If you think you have a warranty situation, regarding material, workmanship, call us before making repairs.

Specialty Manufacturing Company  
Outboard Jets  
2035 Edison Avenue  
San Leandro, CA 94577

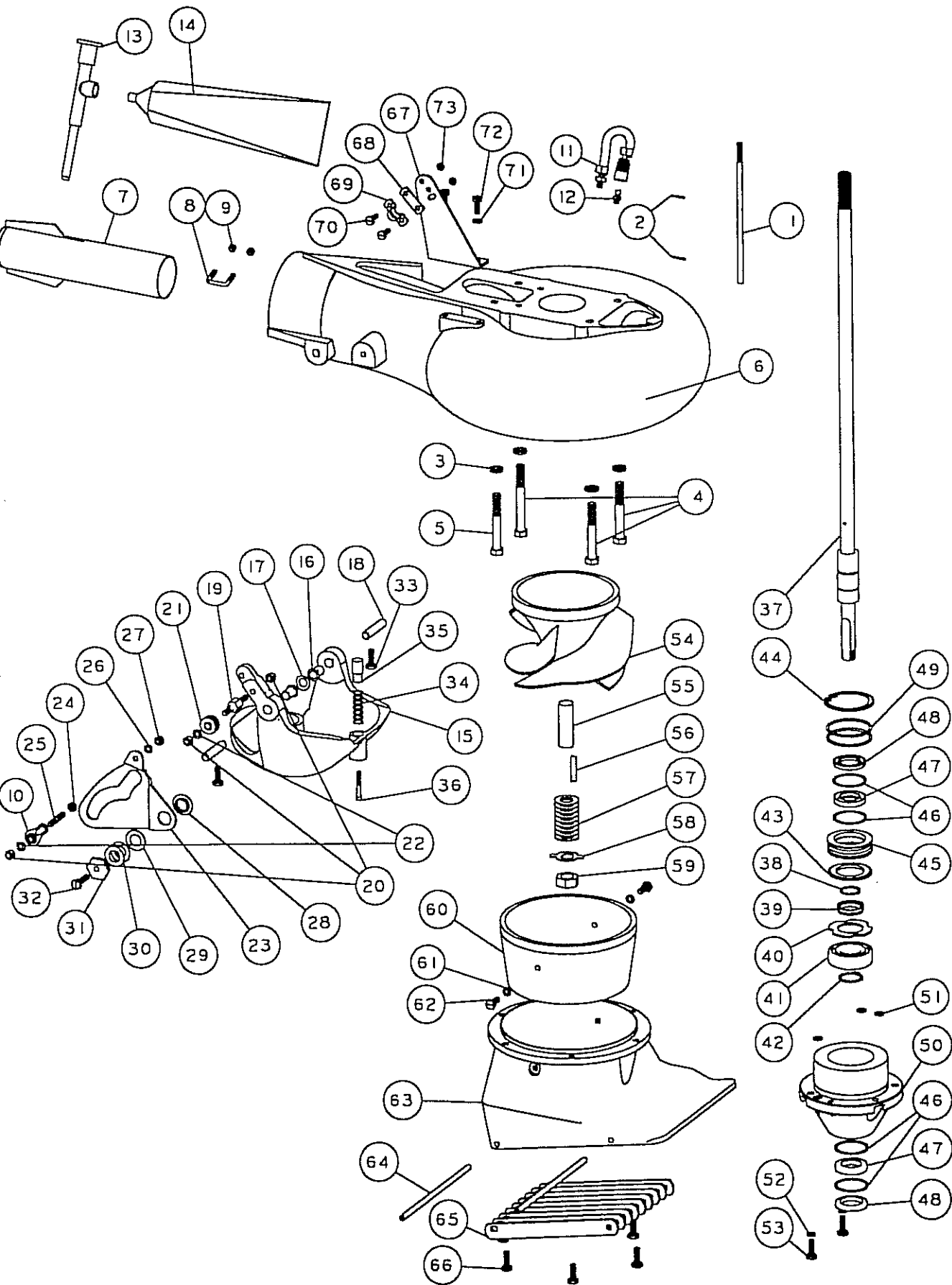

# MODEL J (1980 & LATER) CHRYSLER/FORCE

| REF | QTY | PART NO | DESCRIPTION                          | REF | QTY | PART NO | DESCRIPTION                           |
|-----|-----|---------|--------------------------------------|-----|-----|---------|---------------------------------------|
| 1   | 1   | 174     | SHIFT LOCKOUT CHRYSLER               | 54  | 1   | 8.21    | IMPELLER 5 7/8 W/36 SLEEVE 30/35 HP   |
| 2   | 2   | 645     | COTTER PIN 1/16 X 1/2                | 55  | 1   | 8.22    | IMPELLER 6 1/8 W/36 SLEEVE 40/50 HP   |
| 3   | 4   | 636     | WASHER SPRING LOCK M10               | 56  | 1   | 782     | IMPELLER TEE KEY                      |
| 4   | 3   | 609.1   | BOLT HEX HD 3/8-16 X 2 7/8           | 57  | 9   | 21      | SHIM WASHER MEDIUM                    |
| 5   | 1   | 605     | BOLT HEX HD 3/8-16 X 3 3/8           | 58  | 1   | 805     | NUT KEEPER MED/PKG 2 PER BAG          |
|     |     | 30600   | VOLUTE WITH GATE J                   | 59  | 1   | 22.1    | SHAFT NUT 5/8-18 BRASS                |
| 6   | 1   | 306     | VOLUTE WITH EXHAUST TUBE J           |     |     | 31.1    | INTAKE ASSY 5 7/8 WITH GRILL & LINER  |
| 7   | 1   | 80      | EXHAUST TUBE ASSY MEDIUM 2           | 60  | 1   | 93.21   | LINER 5 7/8 W/HARDWARE 30/35 HP       |
| 8   | 1   | 847     | CLIP EXHAUST TUBE 3/4                |     |     | 31.2    | INTAKE ASSY 6 1/8 WITH GRILL & LINER  |
| 9   | 2   | 621     | NYLOC 10-32                          | 60  | 1   | 93.22   | LINER 6 1/8 W/HARDWARE 40/50 HP       |
| 10  | 1   | 553.2   | BALL END 1/4X10-32 CABLE             | 61  | 2   | 638     | WASHER SPRING LOCK 1/4                |
| 11  | 1   | 975     | LUBE HOSE ASSY                       | 62  | 2   | 572     | BOLT HEX HD 1/4-20 X 5/8              |
| 12  | 1   | 539     | ZIRC FITTING 1/4-28                  | 63  | 1   | 7       | INTAKE PAINTED ONLY                   |
| 13  | 1   | 550     | GREASE GUN                           | 64  | 2   | 14      | GRILL ROD                             |
| 14  | 1   | 552     | GREASE 10 OZ TUBE NO.630-AA          | 65  | 9   | 16      | GRILL BAR MEDIUM                      |
| 15  | 1   | 1175    | REVERSE GATE, MEDIUM                 | 66  | 6   | 573     | BOLT HEX HD 1/4-20 X 3/4              |
| 16  | 2   | 535     | NYLINER 3/8 ID X 11/16               |     |     | 171     | BRACKET ASSY MORSE W/CLAMP & HARDWARE |
| 17  | 1   | 1177    | SPRING GATE PIVOT 3/8                | 67  | 1   | 156     | BRACKET CABLE SUPPORT                 |
| 18  | 2   | 822     | PIN GATE PIVOT 3/8 MEDIUM            | 68  | 1   | 542     | SHIM MORSE A035777                    |
| 19  | 1   | 1043    | SHAFT ROLLER                         | 69  | 1   | 543     | CLAMP CHRYS 154317                    |
| 20  | 3   | 624     | NYLOC 1/4-28                         | 70  | 2   | 561     | FIL HD SLOTTED 10-24 X 5/8            |
| 21  | 1   | 1042    | ROLLER ASSY                          | 71  | 2   | 635     | 1/4 WASHER AN960C416                  |
| 22  | 2   | 635     | 1/4 WASHER AN960C416                 | 72  | 2   | 572     | BOLT HEX HD 1/4-20 X 5/8              |
| 23  | 1   | 1035    | SHIFT CAM MEDIUM                     | 73  | 2   | 619     | NYLOC 10-24                           |
| 24  | 1   | 62      | NUT HEX JAM 1/4-28                   |     |     |         |                                       |
| 25  | 1   | 1199    | PIVOT - CABLE END                    |     |     |         |                                       |
| 26  | 1   | 638     | WASHER SPRING LOCK 1/4               |     |     |         |                                       |
| 27  | 1   | 622     | NUT HEX 1/4-28                       |     |     |         |                                       |
| 28  | 1   | 1037    | BUSHING CAM                          |     |     |         |                                       |
| 29  | 1   | 1038    | WASHER CAM                           |     |     |         |                                       |
| 30  | 2   | 1039    | SHIM - CAM                           |     |     |         |                                       |
| 31  | 1   | 1036    | CAM ECCENTRIC DRILLED                |     |     |         |                                       |
| 32  | 1   | 574.1   | BOLT HEX HD 1/4-20 X 1 PATCH         |     |     |         |                                       |
| 33  | 2   | 574     | BOLT HEX HD 1/4-20 X 3/4 PATCH       |     |     |         |                                       |
| 34  | 1   | 1170    | SPRING GATE BUMPER                   |     |     |         |                                       |
| 35  | 1   | 1169    | GATE BUMPER                          |     |     |         |                                       |
| 36  | 1   | 559.2   | FIL HD SLOTTED 10-32 X 1 1/4 PATCH   |     |     |         |                                       |
|     |     | 308     | SHAFT ASSY COMPLETE, JS, 14T         |     |     |         |                                       |
| 37  | 1   | 305     | SHAFT ONLY, JS, 14T 24 7/16 LG       |     |     |         |                                       |
|     |     | 896     | SHAFT ASSY COMPLETE, JL, 14T         |     |     |         |                                       |
| 37  | 1   | 895     | SHAFT ONLY, JL, 14T 29 7/16 LG       |     |     |         |                                       |
| 38  | 1   | 41      | SHAFT BEARING THRUST RING            |     |     |         |                                       |
| 39  | 1   | 477     | COLLAR BACKFIT 7205                  |     |     |         |                                       |
| 40  | 1   | 832     | THRUST WASHER                        |     |     |         |                                       |
| 41  | 1   | 504     | BEARING 7205B-UA                     |     |     |         |                                       |
| 42  | 1   | 511     | TRUARC 5100-98                       |     |     |         |                                       |
| 43  | 1   | 833     | SPACER                               |     |     |         |                                       |
| 44  | 1   | 512     | TRUARC N5002-212ZD                   |     |     |         |                                       |
| 45  | 1   | 433     | UPPER SEAL CARRIER W/SEALS & O RINGS |     |     |         |                                       |
| 46  | 4   | 517     | SPIROLOX RR-150S                     |     |     |         |                                       |
| 47  | 2   | 506     | SEAL INNER                           |     |     |         |                                       |
| 48  | 2   | 507     | SEAL OUTER 6324-S                    |     |     |         |                                       |
| 49  | 2   | 526     | O RING 568-135 3/32X1 15/16X2 1/8    |     |     |         |                                       |
| 50  | 1   | 303     | BEARING CARRIER W/SEALS & O RINGS J  |     |     |         |                                       |
| 51  | 3   | 521     | O RING 568-011 1/16X5/16X7/16        |     |     |         |                                       |
| 52  | 2   | 638     | WASHER SPRING LOCK 1/4               |     |     |         |                                       |
| 53  | 2   | 573     | BOLT HEX HD 1/4-20 X 3/4             |     |     |         |                                       |

I. AUG. 97

SIZE TORQUE

1/4-20 (M6) 8-9 FT-LBS

5/16-18 (M8) 12

3/8-16 (M10) 22