

MODEL "Q" SERIES
ASSEMBLY INSTRUCTIONS

For Evinrude/Johnson 20-35 HP, 2 cylinder, 31.8 cu.in., 1976 to present

Special 1981 Instructions

The 1980/81 Johnson/Evinrude 35HP motors have two design changes affecting installation of our jet drives.

1. The shift handle has been changed to plastic of a different design. The sheet metal shift arm supplied with this kit has been modified to fit both the new and old designs. Remove the plastic handle, place the metal shift arm in position and replace the plastic handle over the shift arm. Use the 1/4-20 x 1-1/4 socket head bolts in place of the bolts which came with the motor. See page 2.

Then attach and adjust the shift rod as explained on page 4.

2. The gearbox shift rod is of one piece design, without a coupling. To lower the gearbox, the cooling water inlet screens are removed and the shift rod is disconnected at the lower end. The nut is backed off, the split plastic ferrule is removed followed by the nut.

The shift rod, which now hangs below the exhaust housing mounting face, would interfere with the jet drive and must be shortened. CAUTION Using a hacksaw cut exactly 3-7/8 inches off the end. This is more easily done by placing a small wooden block between the rod and the exhaust housing and using a "C" clamp to hold the rod steady against the block and exhaust housing. Do not throw away the end cut off. (see 3) Using a file, bevel the sharp edges of the rod, which will later slide up and down in a guide hole in the jet drive bearing housing.

The 2 small conical plastic seals which surround the shift rod in the cooling pump and the gasket under the stainless steel pump plate are not used in the jet drive. Only the 4 forward pump mounting bolts are used. Be sure to install the 2-1/2 inch long brass cooling water tube extension.

3. If you wish to change back to the propeller drive at a later date, we have available a threading die kit and threaded coupling with instructions for threading the cut off ends of the shift rod. This will make it easy to switch back and forth between prop and jet. The stainless steel coupling costs extra and the cost of the threading kit is refundable after return in good condition. Tool #465, Coupling #464
4. In late 1981 motors, 5/16" bolts have replaced the 1/4" bolts which attach the gearbox to the exhaust housing. The jet drive adapter plate holes and C'bores have been opened up to receive the 5/16" bolts. Both 1/4" and 5/16" bolts and lockwashers are supplied in the kit. If your motor uses 1/4" bolts, use the small bushings supplied to take up the clearance in the adapter plate.

MODEL Q

Shift Rod and Handle Assembly Instructions

Short Shaft #1235, Long Shaft #1237

The 1990 Johnson/Evinrude 20-30 HP Motors have a design change on the tiller steering models.

The shift handle has been moved from the side of the motor to the front.

Fortunately, the mounting pad for the side shift handle has been left in place.

Attach the metal shift arm for the jet drive reverse mechanism to this mounting pad using 2 - 1/4-20 x 7/8 bolts and square nuts.

Then attach and adjust the shift rod as explained on page 4. (Roller at the end of the cam slot in forward position for positive lock.)

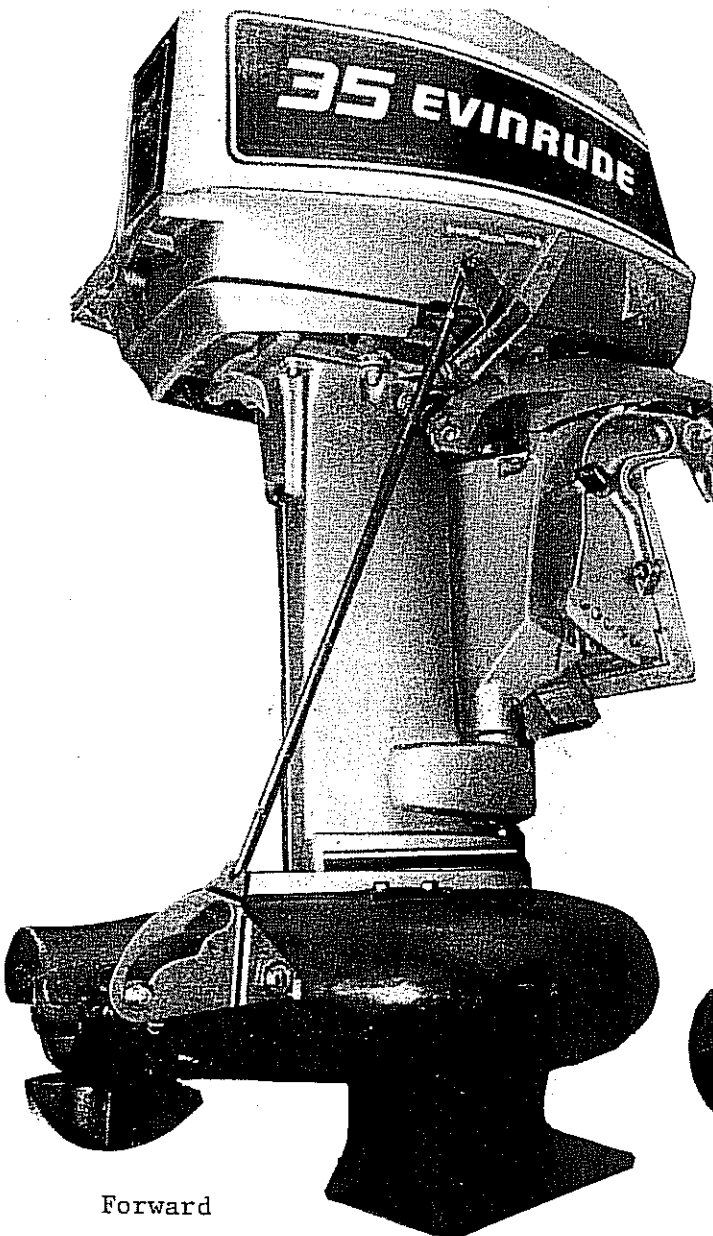

Forward

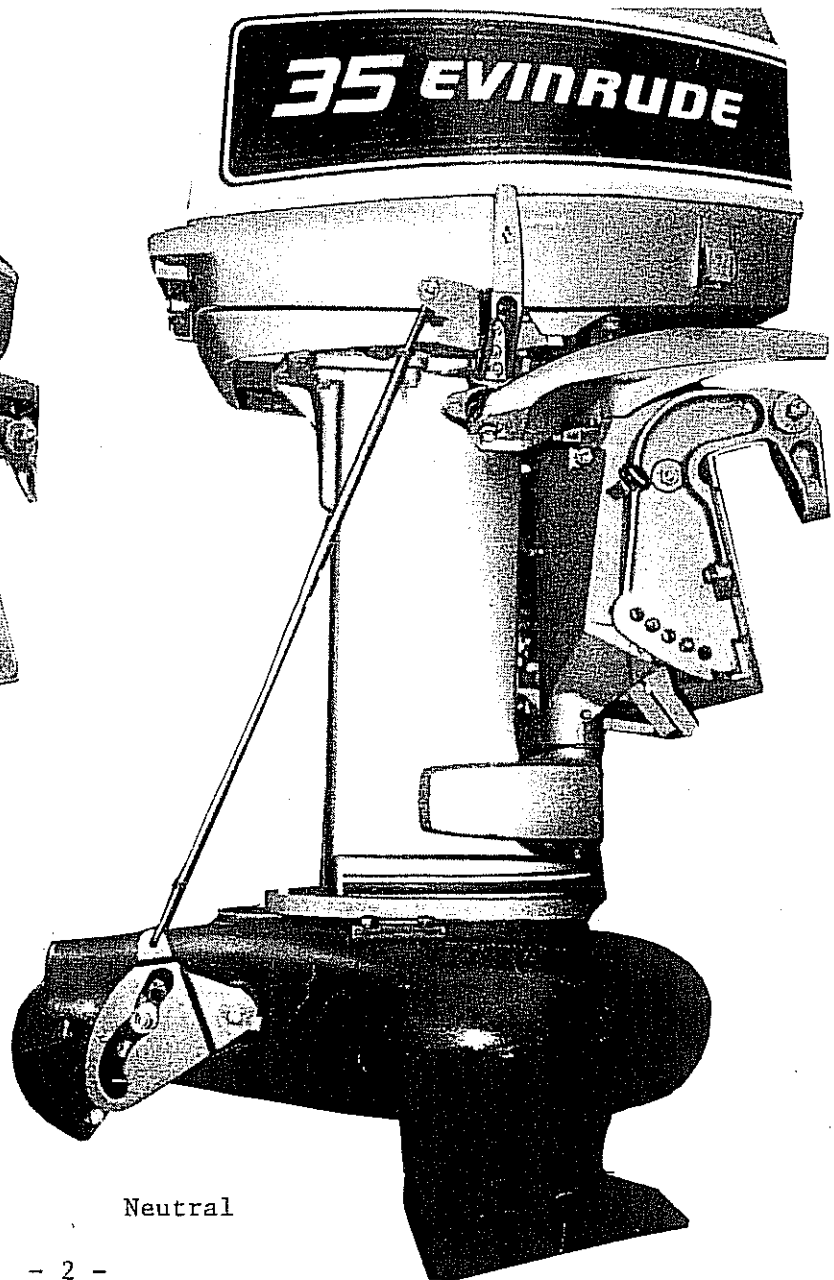

Neutral

MODEL Q

1. Place the engine on the transom of your boat so that it is mounted vertically, in the normal fashion. Open the access plate in the exhaust housing and disconnect the shift rod coupling at the upper cap screw. Remove gearbox cap screws and drop propeller-gearbox assembly.

MOTORS
PRIOR
TO 1980

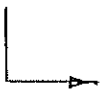

2. In removing the propeller unit it was necessary to disconnect the shift rod at the exhaust housing access hole. This rod would later rattle from vibrations so a spring is provided to urge the loose end of the rod sideways so that it drags in its guide hole. The brass shift rod coupling is removed and the spring is installed with the right angle loop around the groove in the shift rod and the fully bent back loop over the access plate upper screw hole. Leave the access plate gasket in place in the exhaust housing and allow this gasket to wedge between the main body loops of the spring when the flat loop is over the screw hole. This wedging will hold the spring in position long enough to get the plate and screws in place after which the spring loop cannot get out.

3. Next, install the jet pump drive shaft assembly into the spiral pump housing locking it in place with two #10-24 fillister head screws and spring lockwashers.

4. Remove the water pump assembly from the gearbox, including drive key and stainless pump plate. Install this assembly in the jet drive. Be sure the pump is in good condition and that the rubber impeller fingers are all pointing backwards when turning the driveshaft in a clockwise direction looking down from above. Don't forget impeller drive key. Slide the copper water tube extension onto the cooling water tube.
DO NOT USE A GASKET UNDER THE STAINLESS STEEL PUMP PLATE.

5. Slide the aluminum extension onto the plastic driveshaft sealing tube. Grease the "O" ring before installation.

5/16-18
BOLTS
STARTING
1981 → 6. Tip the engine up toward the horizontal. Install the adapter plate on the engine using four 1/4-20 x 1 bolts with lockwashers and one 5/16-18 x 2-1/4 bolt and fiber lock nut, with the nut on top. Be sure to remove the 1/2 inch diameter steel ring from the gearbox assembly and install it in the adapter plate where the 5/16 bolt goes. Tighten all bolts.

7. Grease the driveshaft spline. Install the jet pump housing and shaft assembly onto the engine, using the four 1/4-20 x 2-3/4 screws and lockwashers and the 3/8-16 x 1-1/4 bolt and lockwasher. Be sure, as you guide the unit into position, that the water tube engages the pump. A little grease helps on this rubber coupling. Start all screws into engagement before tightening any one. Tighten the four 1/4-20 screws to 100 in.-lbs. torque (20 lbs. at the end of a five inch wrench for example.)

8. Next, install the impeller. Grease the shaft threads, key and impeller bore. Place the plastic sleeve inside the impeller, hold the key in the nose of the impeller with your forefinger and slide onto the driveshaft. Install the 8 shim washers and nut retainer on the shaft, up against the impeller, and bring the nut up snug by hand. Be careful that the retainer does not fall into the thread groove and jam the nut.

MODEL Q

Place the water intake in position and secure with 2 bolts. Observe the clearance between the impeller blade edge and the intake liner. Then remove the intake.

When, after use in sand and gravel, the blade clearance becomes more than about 1/32" between the impeller edge and the water intake liner, one or more of the stainless shim washers can be transferred from the bottom stack to the top of the impeller, which moves the impeller down into the tapered casing to reduce the clearance.

Shims should not be used above the impeller on new installations, where no wear has occurred, unless the blade clearance exceeds 1/32". Insufficient blade clearance will do more harm than good from any performance gains it might provide.

9. When the impeller clearance is satisfactory, bump the nut up snug with a wrench. If the ears of the retainer do not line up with the flats on the nut, spin the nut off, turn the retainer over and tighten the nut again. In one of these two positions you will have alignment and can fold the ears up against the nut to retain it. The flat in the retainer is angled to the ears to allow this.
10. Place the intake casing in position with the 1/4 inch lip forward and tighten the 6 - 1/4-20 x 3/4 bolts. Use grease on the threads.
11. Attach the metal shift arm as explained on pages 1 and 2. Then place the shift lever in neutral.
12. Using a light finger pressure on the reverse gate, move the gate toward reverse until the cam roller is nested in the neutral notch of the cam. Adjust the length of the shift rod until it engages the cam and shift arm with this neutral setting. Temporarily install a cotter pin in each rod end.
13. Shift to forward. The roller must be at the end of the forward slot in the cam such that the gate cannot be forcibly rotated toward reverse. Pull on the gate by hand to verify this.

If this forward lock condition is not met, readjust the rod length giving less importance to the roller position in neutral. When the adjustment is correct, tighten the rod end nuts, install the coil springs, flat washers and cotter pins in the rod ends.

14. Lubricate the shaft bearing as explained in separate sheet, "Maintenance and Lubrications."

MODEL Q

15. When converting to jet drive, your motor will have to be raised to the height shown below, using a straight edge under the boat. Test run the boat and then raise or lower the motor 1/4" at a time to obtain the best results, using wood shim under the motor clamps. If you raise it too much it will suck air and cavitate, either on start up or when banking on turns. When cavitating, the engine overspeeds in spurts and shakes considerably in the engine mount. This is not a normal condition and should be avoided by proper adjustment of engine height on each individual boat. If you lower it too much you will have excessive drag, therefore mount the engine as high as possible without allowing cavitation. Good boating and have fun!

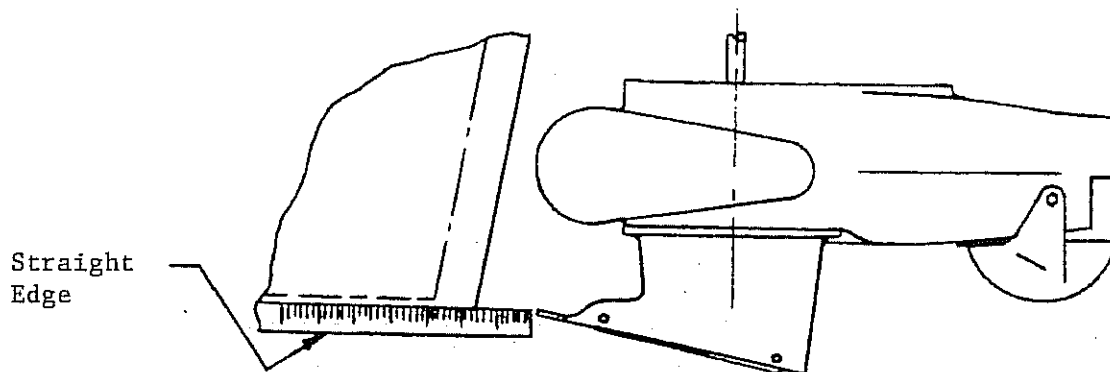

CAUTION!

When starting the engine for the first time, watch to see that cooling water comes out of the cooling water outlet at the rear of the engine just below the powerhead. This is to check your assembly of the cooling water pump and its connections.

MAINTENANCE AND LUBRICATION

See separate sheet.

OUTBOARD JETS
2035 Edison Avenue
San Leandro, California 94577

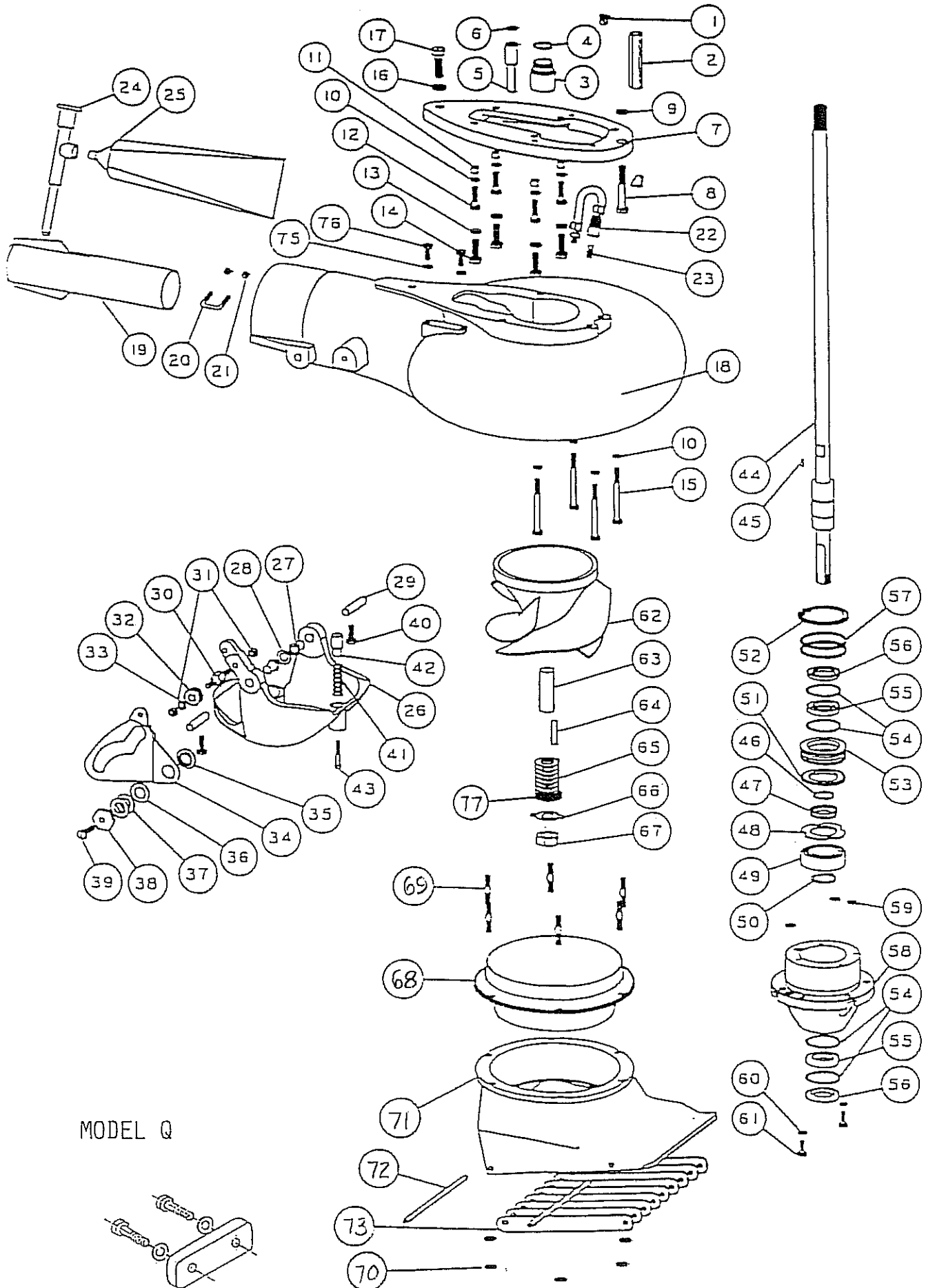

MODEL Q

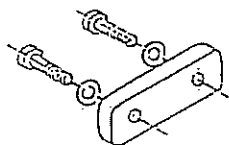

ANODE KIT 1693

MODEL Q JOHNSON / EVINRUDE

REF	QTY	PART NO.	DESCRIPTION	REF	QTY	PART NO.	DESCRIPTION
1	1	28	SHIFT SPRING A H Q	49	1	504	BEARING 7205B-UA
2	1	464	SHIFT ROD COUPLING Q	50	1	511	TRUARC 5100-98
3	1	352.1	SHAFT SHIELD EXT Q	51	1	833	SPACER
4	1	532	O RING 568-018 1/16X3/4X7/8	52	1	512	TRUARC N5002-212ZD
5	1	353.2	WATER TUBE EXTENSION Q	53	1	433	UPPER SEAL CARRIER W/SEALS & O RINGS
6	1	522	O RING 568-012	54	4	517	SPIROLOX RR-150S
7	1	347	ADAPTER PLATE Q	55	2	606	SEAL INNER
8	1	598	BOLT HEX HD 5/16-18 X 2 1/4	56	2	507	SEAL OUTER 6324-S
9	1	625	NYLOC 5/16-18	57	2	526	O RING 568-135
10	8	638	WASHER SPRING LOCK 1/4	58	1	370	BEARING CARRIER W/SEALS & O RINGS Q
11	4	472	BUSHING ADAPTER PLATE Q	59	3	521	O RING 568-011 1/16X5/16X7/16
12	4	576	BOLT HEX HD 1/4-20 X 1	60	2	637	WASHER SPRING LOCK 1/4
13	4	640	WASHER SPRING LOCK 5/16	61	2	561	FIL HD SLOTTED 10-24 X 5/8
14	4	602	BOLT HEX HD 5/16-18 X 1	62	1	8.21	IMPELLER 5 7/8, ALUM/ ZINC, W/36.1 SLEEVE
15	4	581	BOLT HEX HD 1/4-20 X 2 3/4	63	1	36.1	SHAFT SLEEVE PLASTIC MED.
16	1	636	WASHER SPRING LOCK M10	64	1	782	IMPELLER TEE KEY - SQUARE
17	1	606	BOLT HEX HD 3/8-16 X 1 1/4	64	1	1705	IMPELLER TEE KEY - 1/2 ROUND
		35700	VOLUTE WITH GATE Q	65	8	21	SHIM WASHER MEDIUM
18	1	367	VOLUTE WITH EXHAUST TUBE Q	66	1	805	NUT KEEPER MED/PKG 2 PER BAG
19	1	80	EXHAUST TUBE ASSY MEDIUM 2	67	1	22.1	SHAFT NUT 5/8-18 BRASS
20	1	846	CLIP EXHAUST TUBE 1			1448	INTAKE ASSY 5 7/8 FLANGED W/ GRILL & LINER
21	2	621	NYLOC 10-32	68	1	1678	LINER 5 7/8 FLANGED
22	1	975	LUBE HOSE ASSY	69	6	1300	STUD - INTAKE MEDIUM
23	1	539	ZIRC FITTING 1/4-28	70	6	623	NYLOC 1/4-20
24	1	550	GREASE GUN	71	1	1326	INTAKE PAINTED ONLY MED FLANGED
25	1	552	GREASE TUBE NO 630-AA	72	2	14	GILL ROD
26	1	1175	REVERSE GATE, MEDIUM	73	9	16	GILL BAR MEDIUM
27	2	535	NYLINER 3/8 1D X 11/16	75	2	636	1/4 WASHER AN960C416
28	1	1177	SPRING GATE PIVOT 3/8	76	2	572	BOLT HEX HD 1/4-20 X 5/8
29	2	822	PIN GATE PIVOT 3/8 MEDIUM	77	1	1718	TORSIONAL DAMPER 5/8
30	1	1043	SHAFT ROLLER				
31	3	624	NYLOC 1/4-28				
32	1	1042	ROLLER ASSY				
33	2	635	1/4 WASHER AN960C416				
34	1	1035	SHIFT CAM MEDIUM				
35	1	1037	BUSHING CAM				
36	1	1038	WASHER CAM				
37	2	1039	SHIM - CAM				
38	1	1036	CAM ECCENTRIC DRILLED				
39	1	574.1	BOLT HEX HD 1/4-20 X 1 PATCH				
40	2	574	BOLT HEX HD 1/4-20 X 3/4 PATCH				
41	1	1170	SPRING GATE BUMPER				
42	1	1169	GATE BUMPER				
43	1	559.2	FIL HD SLOTTED 10-32 X 1 1/4 PATCH				
		350	SHAFT ASSY COMPLETE, Q SHORT, 14T				
44	1	349	SHAFT ONLY, Q SHORT, 14T, 25 1/2 LG.				
		358	SHAFT ASSY COMPLETE, Q LONG, 14T				
44	1	355	SHAFT ONLY, AM LONG, 14T, 30 1/2 LG.				
45	1	410	KEY ROLL WATER PUMP HQ				
46	1	41	SHAFT BEARING THRUST RING				
47	1	477	COLLAR BACKFIT 7205				
48	1	832	THRUST WASHER				

SIZE	TORQUE
1 /4-20 (M6)	8-9 FT-LBS
5 /16-18 (M 8)	12 FT-LBS
3/8-16 (M10)	22 FT-LBS

TILLER STEERING:

SHIFT ROD ASSY 386, 387, BEFORE CAM GATE
1980 OR OLDER, SEE PAGE 20

SHIFT ROD ASSY 1235, 1237 CAM GATE
1981 OR NEWER, SEE PAGE 34

BEARING, SEAL, SNAP & "O" RING KIT 803.1

MAINTENANCE AND LUBRICATION OUTBOARD JET DRIVE

BEARING LUBRICATION

A grease gun and tube of grease is supplied with your jet drive. We recommend greasing the bearing every 10 hours. Make greasing a part of your cleanup after the days use. Pump in just enough grease to fill the lube hose. Then reconnect the lube hose coupling to the zerk grease fitting.

Every 30-40 hours, pump in extra grease so as to purge any moisture. The texture of the grease coming out gives an indication of conditions inside the bearing housing. A gradual increase in moisture content indicates seal wear. If the grease begins to turn dark, dirty gray, the bearing and seals should be inspected and replaced if necessary. Some discoloration of the grease is normal during the break in period on new sets of seals.

We have selected a water resistant grease of the proper consistency for this application. If you use a substitute grease, be sure it is water resistant and of the same consistency.

IMPELLER

Your jet drive is equipped with a key to protect the unit in the event of a rock jam. This can be reached by removing the water intake, and then the driveshaft nut, similar to a propeller drive. After replacing the key, pull the shaft nut up tight to remove any play between the impeller and shaft. Note the position of the impeller shim washers, and replace them in the same order.

REVERSE GATE MECHANISM

Occasionally check adjustment of the gate shifting linkage. In "forward" the gate should be firmly locked in position. Pull on the gate by hand to verify this. This will prevent wave action from accidentally shifting the gate into reverse as the boat is violently maneuvered

GENERAL

Check all mounting bolts, intake screws, linkage connections, etc., occasionally to be sure they are tight.

SALT WATER USE

Aluminum and stainless steel have been used in the construction of your jet drive. These materials have either been treated or are inherently resistant to corrosion. It is recommended, however, that when not in use the motor be tipped up so that the jet unit is out of the water. When used in salt water more than in fresh water, remove mounting hardware, grease, and reassemble once a year. Failure to do this may result in hardware that is difficult if not impossible to remove at a later date.

GUARANTEE

Due to inflexible government regulation, we do not have a written warranty. We have, however, a good reputation for fairness with our customers which we intend to maintain. If you think you have a warranty situation, regarding material, workmanship, call us before making repairs.

Specialty Manufacturing Company
Outboard Jets
2035 Edison Avenue
San Leandro, CA 94577

SHIFT ROD ASSEMBLY
 EVINRUDE/JOHNSON MODEL Q
 BEFORE CAM GATE
 386 SHORT
 387 LONG

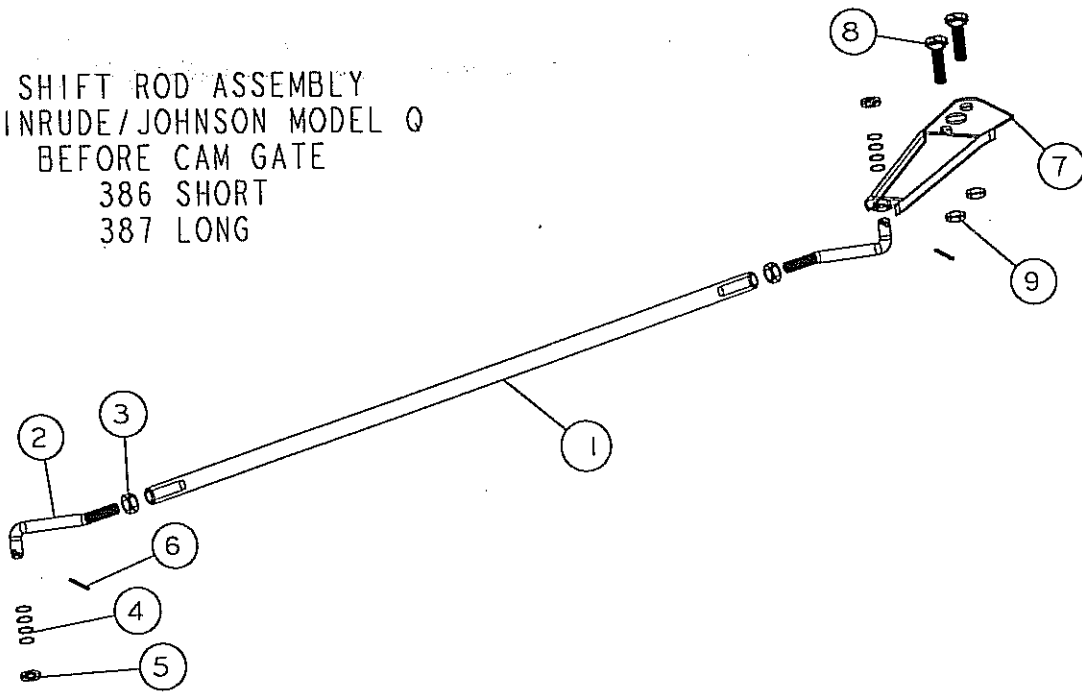

REF	QTY	PART NO	DESCRIPTION
1	1	351	SHIFT ROD Q 15 15/16 SHORT
1	1	364	SHIFT ROD QL 20 1/2 LONG
2	2	24	ROD END FORMED
3	2	622	NUT HEX 1/4-28
4	2	1164	SPRING-ROD END
5	2	635	1/4 WASHER AN960C416
6	2	645	COTTER PIN 1/16 X 1/2
7	1	211	SHIFT LEVER HQ
8	2	575	BOLT HEX HD 1/4-20 X 7/8
9	2	628.1	NUT SQUARE 1/4-20

7. AUG. 97

SHIFT ROD ASSEMBLY
 EVINRUDE/JOHNSON MODEL Q
 TILLER STEERING - CAM GATE
 1235 SHORT
 1237 LONG

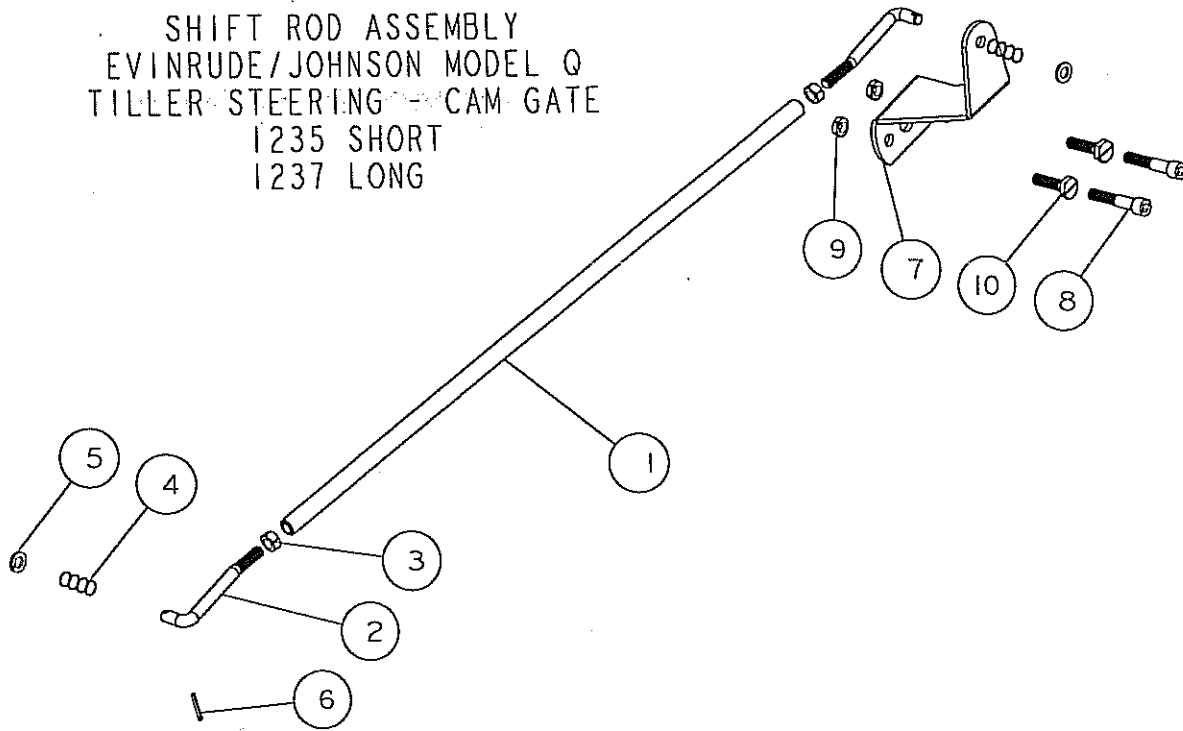

REF	QTY	PART NO	DESCRIPTION
1	1	1234	SHIFT ROD QS CAM 16 1/8 SHORT
1	1	1236	SHIFT ROD QL CAM 21 1/16 LONG
2	2	24	ROD END FORMED
3	2	622	NUT HEX 1/4-28
4	2	1164	SPRING-ROD END
5	2	635	1/4 WASHER AN960C416
6	2	645	COTTER PIN 1/16 X 1/2
7	1	1233	SHIFT LEVER Q CAM
8	2	566	CAP SCR SOC HD 1/4-20X1 1/4 (1989 & PRIOR)
9	2	628.1	NUT SQUARE 1/4-20 (1990 & LATER)
10	2	575	BOLT HEX HD 1/4-20 X 7/8 (1990 & LATER)

2.SEP.97