

Y100-4

MODEL Y SERIES

ASSEMBLY INSTRUCTIONS

For Yamaha Motors 70-100 HP, 1998 to present **4 STROKE**

1. Place the engine on the transom of your boat so that it is mounted vertically, in the normal fashion. Remove the bolts holding the gearbox to the exhaust housing and remove the gearbox assembly.
2. Remove the water pump assembly from the propeller drive, including the lower stainless steel plate, gaskets, impeller drive key, and dowel pins.
3. Install the jet driveshaft assembly into the spiral pump housing locking it in place with the four 5/16-18 x 1 bolts with **LOCK WASHERS**, 12 FT-LBS. No lockwashers are used. Use grease on the threads.
4. Install the water pump assembly on top of the 1-3/8" thick aluminum adapter and stainless steel plate, with gaskets and dowel pins. Be sure also, to install the water pump impeller drive key removed from the propeller drive. Lock in place using four 5/16-18 bolts and lockwashers. Grease the threads.
5. The large 3/4" adapter plate is attached to the exhaust housing to hold the jet drive. A 3/8 x 1-1/2 pin in the front of the plate guides the disconnected shift rod. Two 6 x 16mm dowels locate the plate, four M10 x 35mm bolts with lockwashers and one M8 x 30mm bolt with lockwasher secure it, 22 FT-LBS. Grease bolt threads and the end of the pin where it slides in the shift rod.
6. Next attach the jet drive to the motor. Two 3/16 x 1/2 dowel pins center the jet drive on the adapter plate. Four 3/8-16 bolts and lockwashers from below and one 3/8-16 x 1-1/4 bolt from above rear, are used. Select the lower bolt lengths to suit the different counter bore depths so that all bolts enter the adapter plate the same depth, 22 FT-LBS.

Grease the bolt threads, driveshaft spline generously, and rubber water tube pilot and guide the jet into place. Tighten the five bolts.

7. Next, install the impeller. Grease the shaft threads, key and impeller bore. Place the plastic sleeve inside the impeller, hold the key in the nose of the impeller with your forefinger and slide onto the driveshaft. Install the eight shim washers and nut retainer on the shaft, up against the impeller, and bring the nut up snug by hand. Be careful that the retainer does not fall into the thread groove and jam the nut.

Then bump the nut with a wrench. If the ears of the retainer do not line up with the flats on the nut, spin the nut off, turn the retainer over and tighten the nut again. In one of these two positions you will have alignment and can fold the ears up against the nut to retain it. The flat in the retainer is angled to the ears to allow this.

When, after use in sand and gravel, the blade clearance becomes more than about 1/32" between the impeller edge and the water intake casing wall, one or more of the shim washers can be transferred from the bottom stack to the top of the impeller, which moves the impeller down into the tapered casing to reduce the clearance.

MODEL Y

Shims should not be used above the impeller on new installations where no wear has occurred, unless the blade clearance exceeds 1/32 inch. Insufficient blade clearance will do more harm than good from any performance gains it might provide.

8. Place the intake casing in position with the lower end at the rear and tighten the six nuts, 12 FT-LBS. No lockwashers are used. Grease the threads.
9. Attach the shift cable and cable anchor bracket to the jet drive.

With the shift handle in forward and the reverse gate in forward, with the cam roller at the end of the slot, adjust the cable end and/or cable anchor position to this condition. Shift to reverse and back to forward. The roller should be at the end of the cam slot such that the gate cannot be forcibly rotated toward reverse. Pull on the gate by hand to verify this.

If this forward lock condition is not met, readjust the cable positions.

10. When converting to jet drive, your motor will have to be raised to height shown in the diagram on page 3, using a straight edge under the boat. Test run the boat and then raise or lower the motor 5/16 inch at a time to obtain the best results.

The motor has four sets of upper mounting holes. You will use one set to begin with. Mark pencil lines on the boat transom through the other sets. Then if you wish to go up or down 5/16 inch, you can drill one alternate set of holes 5/16 inch up or down from the pencil marks. By alternating between these two sets of transom holes and the four sets of motor holes, the motor can be moved in 5/16 inch increments over almost one inch. The transom height should be about 26 inches measured vertically from the boat bottom.

If you raise it too much it will suck air and cavitate, either on start up or when banking on turns. When cavitating, the motor overspeeds in spurts and shakes considerably in the motor mount. This is not a normal condition and should be avoided by proper adjustment of motor height on each individual boat. If you lower it too much you will have excessive drag, therefore mount the motor as high as possible without allowing cavitation.

MODEL Y

CAUTION

When starting the engine for the first time, watch to see that cooling water comes out of the small hole at the rear side of engine just below the powerhead. This is to check your assembly of the cooling water pump and its connections.

The cooling system can be flushed by removing the slotted screw next to the grease fitting. A hose coupling is available from a YAMAHA dealer. Turn on the water gently, start the motor, set to idle and watch for cooling water at the tell tale. Adjust water pressure if needed. Replace the screw after flushing.

MAINTENANCE AND LUBRICATION

See separate sheet.

GOOD BOATING AND HAVE FUN!

PROPER ENGINE HEIGHT

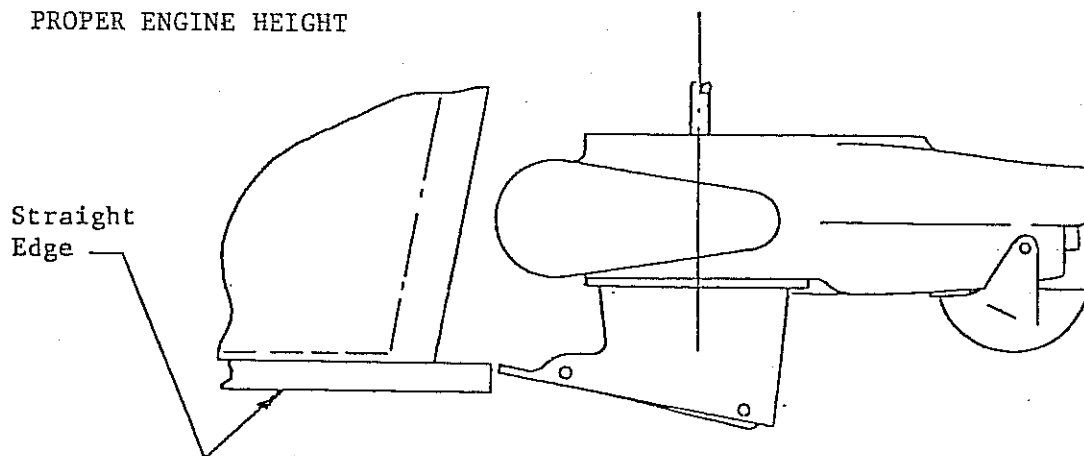

Specialty Manufacturing Company
Outboard Jets
2035 Edison Avenue
San Leandro, CA 94577

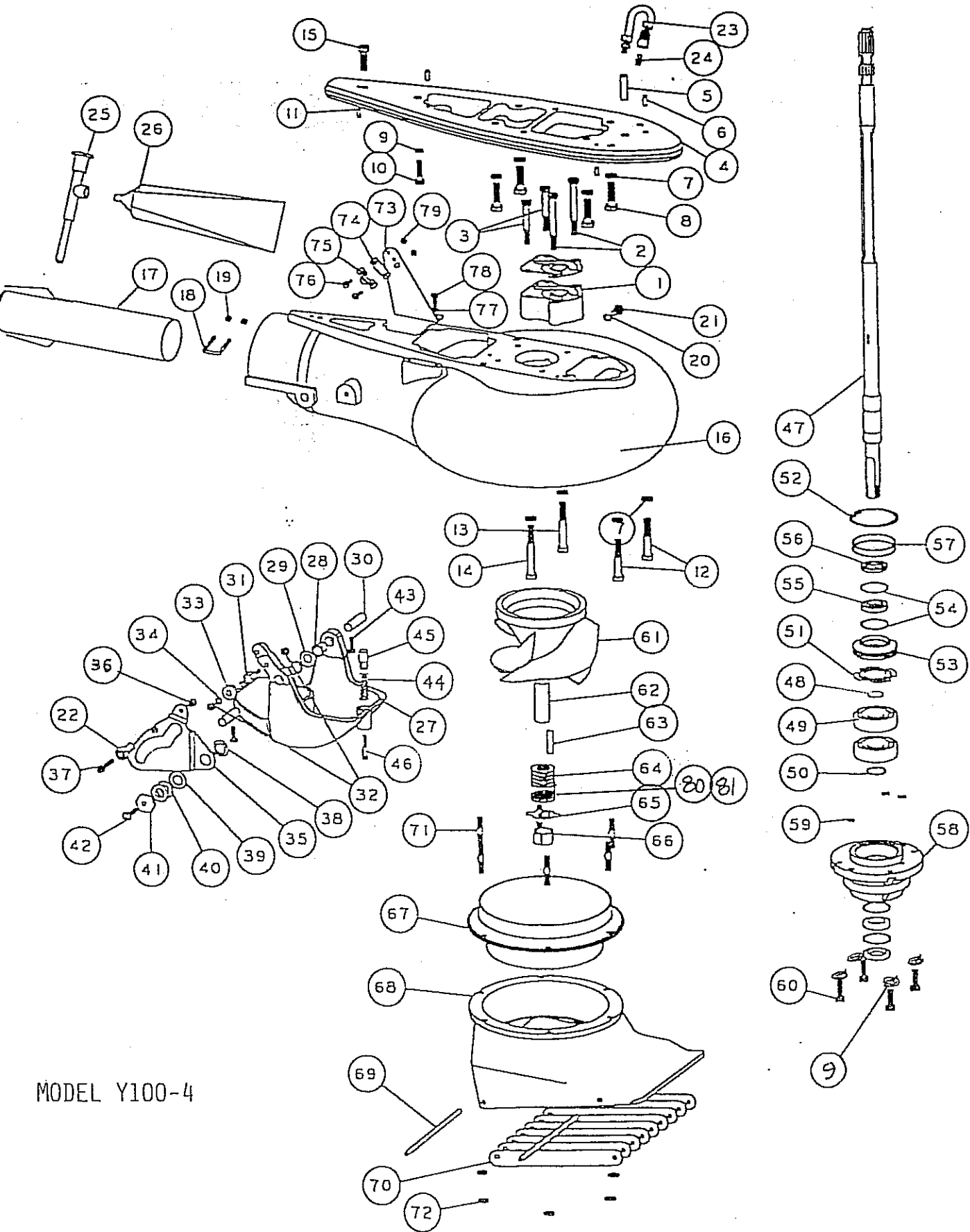

MODEL Y100-4

MODEL Y100-4 YAMAHA

REF	QTY	PART NO.	DESCRIPTION	REF	QTY	PART NO.	DESCRIPTION
1	1	873	PUMP ADAPTER, Y	51	1	404	BACKUP WASHER
2	2	600.1	BOLT HEX HD 5/16-18 X 3 1/2	52	1	513	TRUARC N5002-250ZD
3	2	603	BOLT HEX HD 5/16-18 X 2 1/2	53	1	432	UPPER SEAL CARRIER W/SEALS & "O" RINGS
4	1	871	ADAPTER PLATE Y	54	4	517	SPIROLOX RR-150S
5	1	874	SHIFT GUIDE Y	55	2	506	SEAL INNER
6	2	616	DOWEL PIN 6 X 16MM	56	2	507	SEAL OUTER 6324-S
7	8	636	WASHER SPRING LOCK M10	57	2	527	O RING 568-141 3/32 X 2-5/16 X 2-1/2
8	4	592	BOLT HEX HD M10-1.25 X 35MM	58	1	393.5	BEARING CARRIER W/SEALS & O'RINGS 5/16
9	9	640	WASHER SPRING LOCK 5/16	59	3	521	O RING 568-011 1/16 X 5/16 X 7/16
10	1	591	BOLT HEX HD M8 - 1.25 X 30MM	60	4	602.1	BOLT HEX HD 5/16-18 X 1 PATCH
11	2	631	DOWEL PIN 3/16 X 1/2	61	1	1756	IMPELLER 7 3/8 STAINLESS W/136 SLEEVE
12	2	608	BOLT HEX HD 3/8-16 X 2 1/4	62	1	136	SHAFT SLEEVE PLASTIC LARGE
13	1	609	BOLT HEX HD 3/8-16 X 2 3/4	63	1	434	IMPELLER TEE KEY - SQUARE
14	1	610	BOLT HEX HD 3/8-16 X 3	63	1	1706	IMPELLER TEE KEY - 1/2 ROUND
15	1	606	BOLT HEX HD 3/8-16 X 1 1/4	64	8	121	SHIM WASHER LARGE
		90800	VOLUTE WITH GATE Y	65	1	781	NUT KEEPER LARGE/PKG. 2 PER BAG
16	1	908	VOLUTE WITH EXHAUST TUBE Y	66	1	122.1	SHAFT NUT 3/4-16 BRASS
17	1	128	EXHAUST TUBE ASSY LARGE 2 1/2			1333	INTAKE ASSY FLANGED WITH GRILL LINER
18	1	845	CLIP EXHAUST TUBE 1 3/8	67	1	1431	LINER 7 3/8 FLANGED
19	2	621	NYLOC 10-32	68	1	1332	INTAKE PAINTED ONLY
20	1	1025	WASHER FIBER M8	69	2	14	GRILL ROD
21	1	1024	BOLT HEX HD M8 X 1.25 X 12MM	70	9	117	GRILL BAR LARGE
22	1	563.2	BALL END 1/4 X 10-32 CABALE	71	6	1319	STUD-INTAKE LARGE
23	1	975	LUBE HOSE ASSY.	72	6	625	NYLOC 5/16-18
24	1	539	ZIRC FITTING 1/4-28			171	BRACKET ASSY MORSE W/CLAMP & HDW
25	1	550	GREASE GUN	73	1	156	BRACKET CALBE SUPPORT
26	1	552	GREASE, 10 OZ TUBE NO. 630-AA	74	1	542	SHIM MORSE AO35777
27	1	1172	REVERSE GATE LARGE	75	1	543	CLAMP CHRYS 154317
28	2	536	NYLINER 1/2 ID X 13/16	76	2	561	FIL HD SLOTTED 10-24 X 5/8
29	2	1178	SPRING GATE PIVOT 1/2	77	2	635	1/4 WASHER AN960C416
30	2	823	PIN GATE PIVOT 1/2 LARGE	78	2	572	BOLT HEX HD 1/4-20 X 5/8
31	1	1043	SHAFT ROLLER	79	2	619	NYLOC 10-24
32	2	624	NYLOC 1/4-28	80	1	1719	TORSIONAL DAMPER 3/4
33	1	1042	ROLLER ASSY	81	4	640	WASHER SPRING LOCK 5/16
34	1	635	1/4 WASHER AN960C416				
35	1	1034	SHIFT CAM LARGE				
36	1	623	NYLOC 1/4-20				
37	1	573	BOLT HEX HD 1/4-20 X 3/4				
38	1	1037	BUSHING CAM				
39	1	1038	WASHER CAM				
40	2	1039	SHIM-CAM				
41	1	1036	CAM ECCENTRIC DRILLED				
42	1	574.1	BOLT HEX HD 1/4-20 X 1 PATCH				
43	2	574	BOLT HEX HD 1/4-20 X 3/4 PATCH				
44	1	1170	SPRING GATE BUMPER				
45	1	1497	GATE BUMPER				
46	1	559.2	FIL HD SLOTTED 10-32 X 1-1/4 PATCH				
		1563.1	SHAFT ASSY COMPLETE, Y100-4, 18T 5/16				
47	1	1562	SHAFT ONLY, Y100-4, 18T				
48	1	41	SHAFT BEARING THRUST RING				
49	2	502	BEARING 7305B-UA				
50	1	511	TRUARC 5100-98				

SIZE	TORQUE
1/4-20 (M6)	8-9 FT-LBS
5/16-18 (M8)	12 FT-LBS
3/8-16 (M10)	22 FT-LBS

TILLER STEERING

SHIFT CABLE ASSY 1566, SEE PG. 26.1, THROUGH 2005
2006 SHIFT CABLE ASSY 1857, SEE PG. 26.9

BEARING, SEAL, SNAP & "O" RING KIT, 2 BRG 462.2

MAINTENANCE AND LUBRICATION OUTBOARD JET DRIVE

BEARING LUBRICATION

A grease gun and tube of grease is supplied with your jet drive. We recommend greasing the bearing every 10 hours. Make greasing a part of your cleanup after the days use. Pump in just enough grease to fill the lube hose. Then reconnect the lube hose coupling to the zerk grease fitting.

Every 30-40 hours, pump in extra grease so as to purge any moisture. The texture of the grease coming out gives an indication of conditions inside the bearing housing. A gradual increase in moisture content indicates seal wear. If the grease begins to turn dark, dirty gray, the bearing and seals should be inspected and replaced if necessary. Some discoloration of the grease is normal during the break in period on new sets of seals.

We have selected a water resistant grease of the proper consistency for this application. If you use a substitute grease, be sure it is water resistant and of the same consistency.

IMPELLER

Your jet drive is equipped with a key to protect the unit in the event of a rock jam. This can be reached by removing the water intake, and then the driveshaft nut, similar to a propeller drive. After replacing the key, pull the shaft nut up tight to remove any play between the impeller and shaft. Note the position of the impeller shim washers, and replace them in the same order.

REVERSE GATE MECHANISM

Occasionally check adjustment of the gate shifting linkage. In "forward" the gate should be firmly locked in position. Pull on the gate by hand to verify this. This will prevent wave action from accidentally shifting the gate into reverse as the boat is violently maneuvered

GENERAL

Check all mounting bolts, intake screws, linkage connections, etc., occasionally to be sure they are tight.

SALT WATER USE

Aluminum and stainless steel have been used in the construction of your jet drive. These materials have either been treated or are inherently resistant to corrosion. It is recommended, however, that when not in use the motor be tipped up so that the jet unit is out of the water. When used in salt water more than in fresh water, remove mounting hardware, grease, and reassemble once a year. Failure to do this may result in hardware that is difficult if not impossible to remove at a later date.

GUARANTEE

Due to inflexible government regulation, we do not have a written warranty. We have, however, a good reputation for fairness with our customers which we intend to maintain. If you think you have a warranty situation, regarding material, workmanship, call us before making repairs.

Specialty Manufacturing Company
Outboard Jets
2035 Edison Avenue
San Leandro, CA 94577

SHIFT CABLE ASSEMBLY
 MODEL Y100-4
 TILLER STEERING
 1566

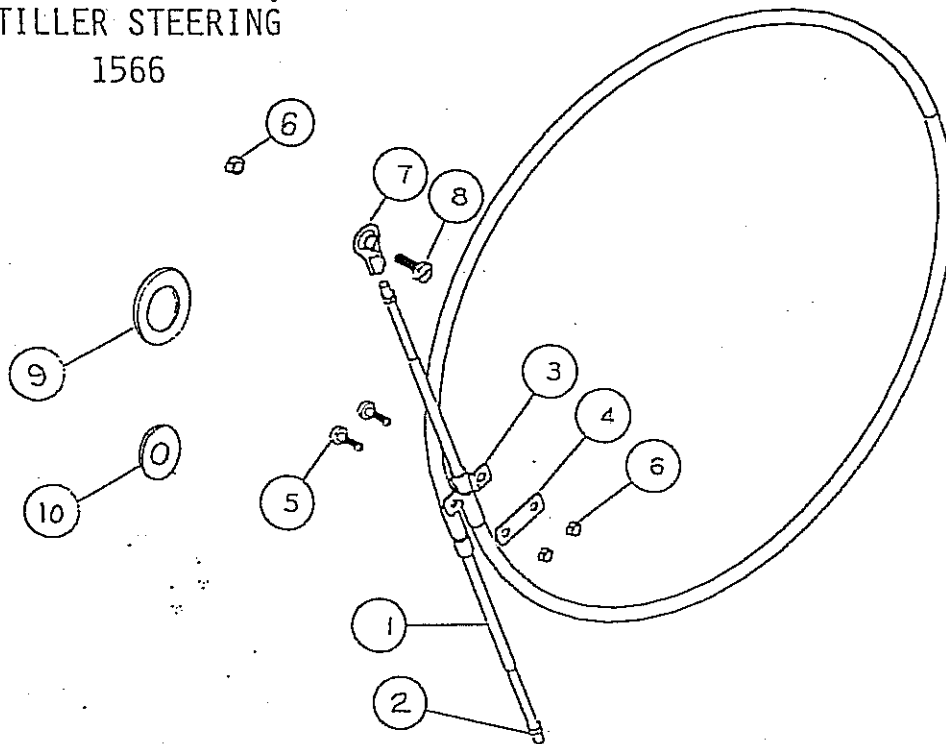

REF	QTY	PART NO	DESCRIPTION
1	1	547.2	CABLE 5 FT MOR 33C SUPREME
2	2	621.1	HEX NUT 10-32 JAM
3	1	543	CLAMP CHRYS 154317
4	1	542	SHIM MORSE A035777
5	2	558	FIL HD SLOTTED 10-32 X 1 1/4
6	3	621	NYLOC 10-32
7	1	553.1	BALL END #10x10 - 32 CABLE
8	1	1567	SCREW HEX HD 10-32 X 3/4 MOD
9	1	1568	SHIM WASHER LARGE
10	1	1569	SHIM WASHER SMALL

TILLER SHIFT CABLE ASSY
YAMAHA STARTING 2006
1856 SHORT
1857 LONG

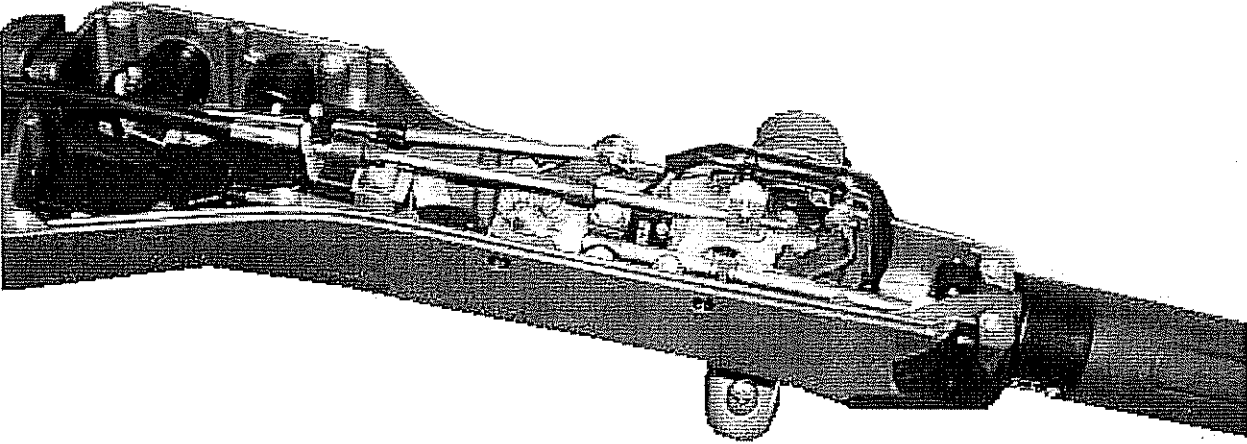

1. Remove the lower plastic cover from the steering handle.
2. Remove the shift cable.
3. Install the 4 1/2 ft. or 5 ft. standard 33C cable, using the cable end 1851.
4. Attach the lower end of the cable to the jet drive with the ball rod end threaded on the cable as far as it will go and the cable anchor bracket centered and locked. Twist the cable in the U-clamp so that the cable rests against the motor cowling and tighten the clamp screws. The clamp base is slotted to allow alignment for minimum cable bending.
5. Place the shift handle in forward, solidly in the detent. The reverse gate cam roller must be at the end of the slot in the cam. If these conditions are not met, slide the cable anchor bracket on the jet drive and/or adjust the threaded rod end on the cable.
6. Shift to reverse and back to forward. Do not be concerned if the gate does not reach reverse. There is clearance at this position and water pressure will close the gate.
7. In forward, with the roller at the end of the cam slot, the gate cannot be forcibly rotated toward reverse. Pull on the gate by hand to verify this.
8. Lock the nuts on the cable against the rod ends to complete the adjustment and reassemble the lower cover of the steering arm.

CAUTION

**YOU MUST RETURN THE THROTTLE
TO IDLE BEFORE SHIFTING.**

TILLER SHIFT CABLE ASSY
 YAMAHA STARTING 2006
 1856 SHORT
 1857 LONG

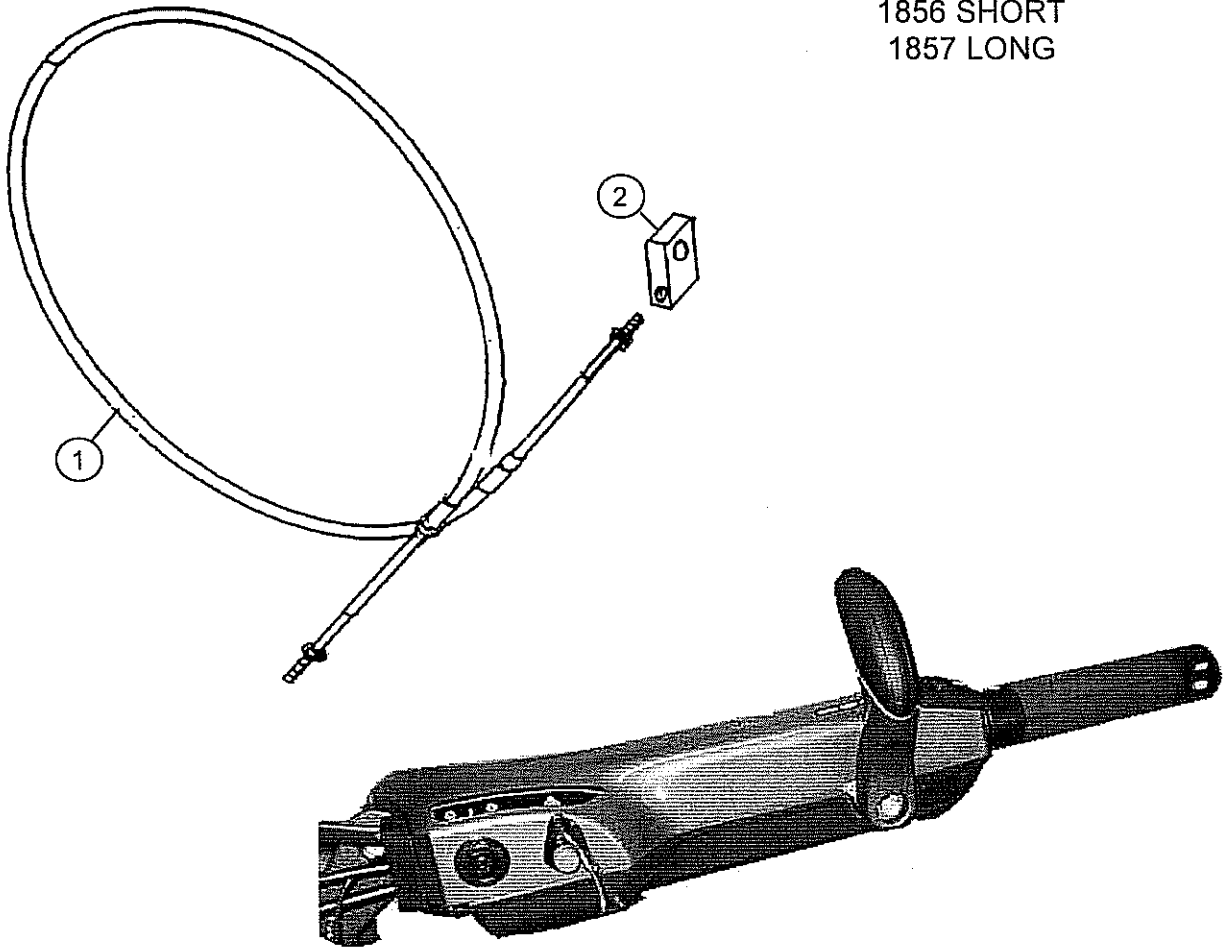

REF	QTY	PART NO.	DESCRIPTION
1	1	547.1	CABLE 4 1/2 FT MOR 33C SUPREME LONG
1	1	547.2	CABLE 5 FT MOR 33C SUPREME LONG
2	1	1851	CABLE END YAMAHA 2006 TILLER