

## MODEL Z SERIES

### ASSEMBLY INSTRUCTIONS

For Yamaha Motors 40, 50 HP, 1983 to 1994, 30 HP since 1987

1. Place the engine on the transom of your boat so that it is mounted vertically, in the normal fashion. Disconnect the shift rod by backing off the hex nuts, lower front. Remove the bolts holding the gearbox to the exhaust housing and remove the gearbox assembly.
2. Remove the water pump assembly from the propeller drive, including the lower stainless steel plate, gasket, impeller drive key and dowel pins.
3. Install the jet driveshaft assembly into the spiral pump housing locking it in place with the two #10-24 x 5/8 screws and lockwashers. Use grease on the threads.
4. Install the water pump assembly on top of the 1-5/16" thick aluminum adapter and stainless steel plate. Be sure also, to install the water pump impeller brass tee key (Woodruff key no longer used), and dowel pins. Lock in place using two 5/16-18 x 2-1/4 and two 5/16-18 x 2-3/4 bolts and lockwashers. Grease the threads.
5. Push the sponge rubber sleeve up inside the pivot tube to prevent the disconnected shift rod from rattling.
6. The large 3/4" adapter plate is attached to the exhaust housing to hold the jet drive. Two 6 x 16mm dowels locate the plate, four M10 x 35mm bolts with lockwashers and one M8 x 30mm bolt with lockwasher secure it. Grease the bolt threads.
7. Next, attach the jet drive to the motor. Two 3/16 x 1/2 dowel pins center the jet drive on the adapter plate. Four 5/16-18 x 2-3/4 bolts and lockwashers from below and one 3/8-16 x 1-1/4 bolt from above rear, are used.  
  
Grease the bolt threads, driveshaft spline generously, and rubber water tube pilot and guide the jet into place. Tighten the five bolts.
8. Next, install the impeller. Grease the shaft threads, key and impeller bore. Place the plastic sleeve inside the impeller, hold the key in the nose of the impeller with your forefinger and slide onto the driveshaft. Install the nine shim washers and nut retainer on the shaft, up against the impeller, and bring the nut up snug by hand. Be careful that the retainer does not fall into the thread groove and jam the nut.

Place the water intake in position and secure with 2 bolts. Observe the clearance between the impeller blade edge and the intake liner. Then remove the intake.

When, after use in sand and gravel, the blade clearance becomes more than about 1/32" between the impeller edge and the water intake liner, one or more of the stainless shim washers can be transferred from the bottom stack to the top of the impeller, which moves the impeller down into the tapered casing to reduce the clearance.

Shims should not be used above the impeller on new installations, where no wear has occurred, unless the blade clearance exceeds 1/32". Insufficient blade clearance will do more harm than good from any performance gains it might provide.

## MODEL Z

When the impeller clearance is satisfactory, bump the nut up snug with a wrench. If the ears of the retainer do not line up with the flats on the nut, spin the nut off, turn the retainer over and tighten the nut again. In one of these two positions you will have alignment and can fold the ears up against the nut to retain it. The flat in the retainer is angled to the ears to allow this.

9. Place the intake casing in position with the lower end at the rear and tighten the six 1/4-20 x 3/4 hex head bolts. No lockwashers are used. Grease the threads. See diagram page 3.
10. If your jet drive was ordered for use with a steering tiller handle, see attached page "Shift Rod and Handle Assembly Instructions", pages 4-6.
11. If your motor is equipped for remote controls, proceed as follows:

Attach the shift cable and cable anchor bracket to the jet drive.

Using a light finger pressure on the gate, move the gate toward reverse until the cam roller is nested in the neutral notch of the cam.

Adjust the shift cable end and the cable anchor bracket on the jet drive such that the roller is in the neutral notch when the shift handle is in neutral. Tighten hardware.

Shift to forward. The roller should be well onto the flat section of the cam such that the gate cannot be forcibly rotated toward reverse. Pull on the gate by hand to verify this.

If this forward lock condition is not met, readjust the cable positions, giving less importance to the roller position in neutral.

12. If the neutral position is too far out of adjustment, the tendency of the gate to move toward reverse, under water pressure, will put tension on the cable in neutral. In some remote control boxes, this makes it difficult to re-engage the shift mode with the motor running in the high speed idle, cold start setting. It is then necessary to stop the motor, operate the shift handle to engage the shifting pin and then restart the motor.

Proper cable adjustment will prevent this problem but it is most important that the forward locking condition be met if a compromise is to be made.

13. When converting to jet drive, your motor will have to be raised to height shown in diagram on page 3, using a straight edge under the boat. Test run the boat and then raise or lower the motor 5/16 inch at a time to obtain the best results.

The motor has four sets of upper mounting holes. You will use one set to begin with. Mark pencil lines on the boat transom through the other sets. Then if you wish to go up or down 5/16 inch, you can drill one alternate set of holes 5/16 inch up or down from the pencil marks. By alternating between these two sets of transom holes and the four sets of motor holes, the motor can be moved in 5/16 inch increments over almost one inch. The transom height should be about 21" measured vertically from the boat bottom for short shaft motors and 26" for long shaft.

## MODEL Z

If you raise it too much it will suck air and cavitate, either on start up or when banking on turns. When cavitating, the motor overspeeds in spurts and shakes considerably in the motor mount. This is not a normal condition and should be avoided by proper adjustment of motor height on each individual boat. If you lower it too much you will have excessive drag, therefore mount the motor as high as possible without allowing cavitation.

### CAUTION

When starting the engine for the first time, watch to see that cooling water comes out of the small hole at the rear side of engine just below the powerhead. This is to check your assembly of the cooling water pump and its connections.

The cooling system can be flushed by removing the slotted screw next to the grease fitting. A hose coupling No. 24789A1 is available from a Mercury dealer. Turn on the water gently, start the motor, set to idle and watch for cooling water at the tell tale. Adjust water pressure if needed. Replace the screw after flushing.

### MAINTENANCE AND LUBRICATION

See separate sheet

GOOD BOATING AND HAVE FUN!

### PROPER ENGINE HEIGHT

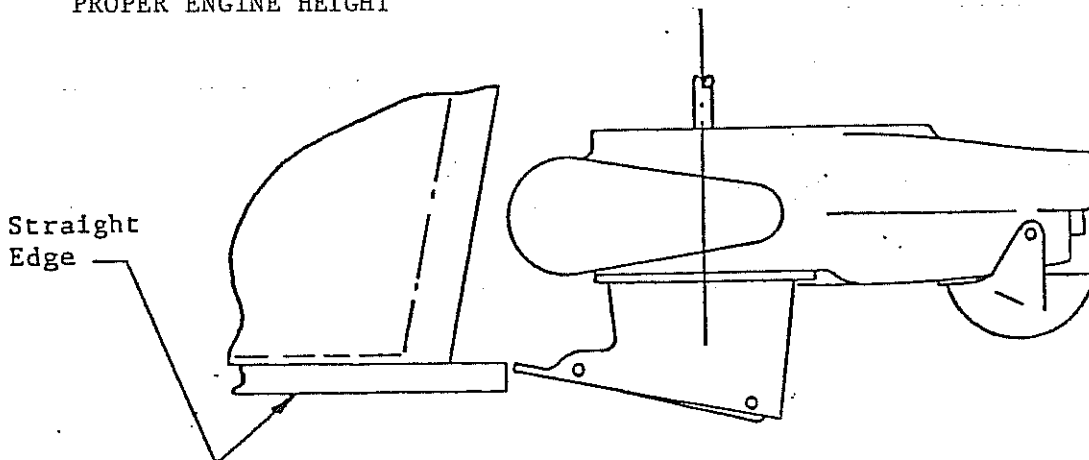

Specialty Manufacturing Company  
Outboard Jets  
2035 Edison Avenue  
San Leandro, CA 94577

MODEL ZSM 40 HP

Shift Rod and Handle Assembly Instructions

Short Shaft #1215, Long Shaft #1217

1. Place the pressed steel shift handle on the motor shift handle and clamp in place, spaced  $3/4$  inch as shown in the diagram. Using a  $3/16$  inch drill, drill through the shift handle for the #10-32 fil head screws. Install the screws and fiber lock nuts. Attach the black knob on top of the spacer and tighten the bolt.
2. Next, attach the shift rod. Using a light finger pressure on the reverse gate, move the gate toward reverse until the cam roller is nested in the neutral notch of the cam. Adjust the length of the rod so that with the handle in neutral, the roller on the reverse gate is in the neutral notch of the cam, with the gate held up by hand.
3. Shift to forward. The roller should be at the end of the slot in the cam such that the gate cannot be forcibly rotated toward reverse. Pull on the gate by hand to verify this. If this forward lock position is not met, readjust the rod length, giving less importance to neutral. Lock the rod end nuts.
4. Return to page 2, paragraph 13 and proceed with setting motor height.

Specialty Mfg. Co.  
2035 Edison Avenue  
San Leandro, CA  
94577

12/11/90

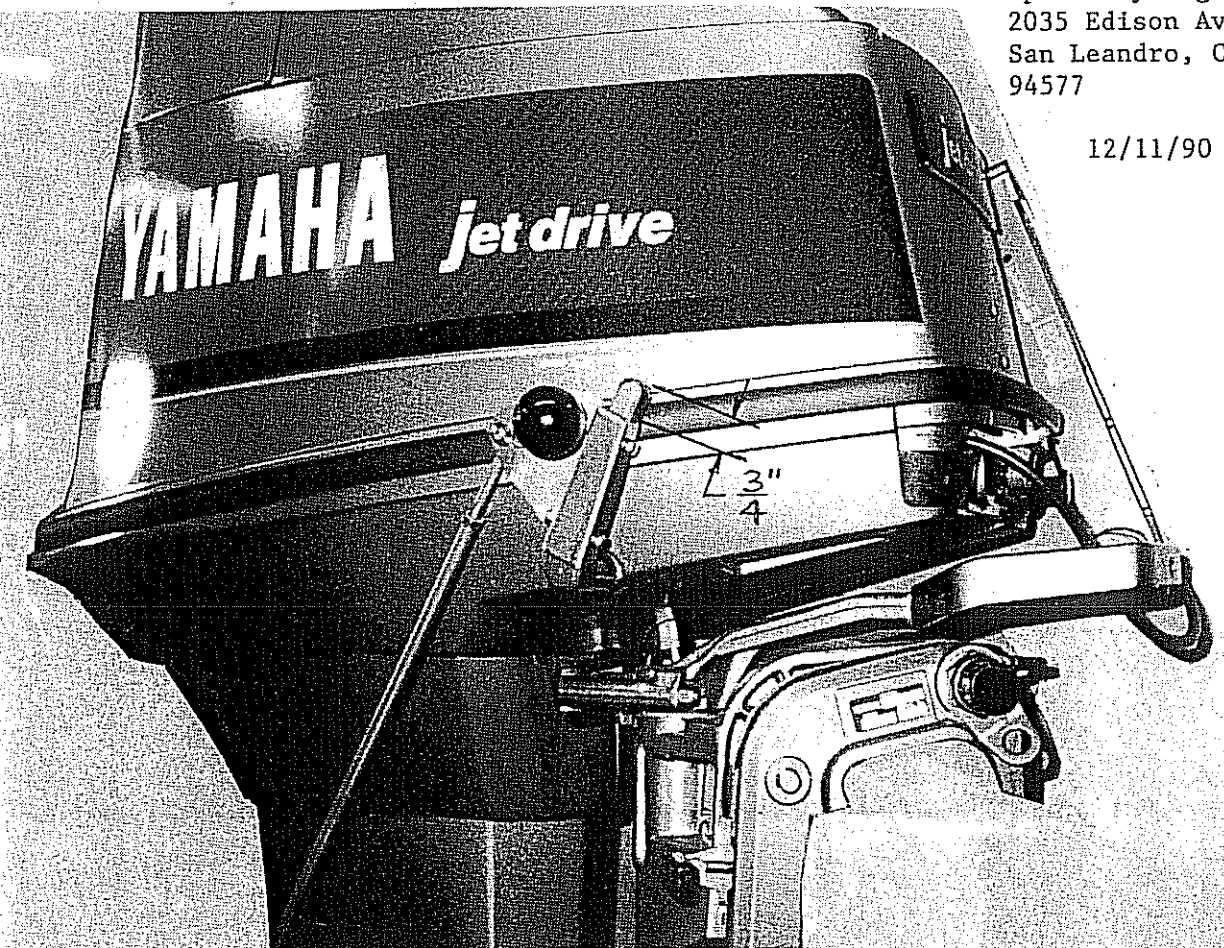

MODEL Z30SM 30 HP

Shift Handle and Cable Assembly Instructions

Short Shaft #1261  
LONG SHAFT #1262

1. Cut out the paper template, bottom of this page. Align the template on the motor cowl and hold in place with masking tape. Drill 2 - 3/16 inch holes and remove template.
2. Attach the cable anchor bracket using 2 - #10-32 x 1 fil head screws and fiber lock nuts.
3. Place the cable end ball bracket in position on the shift handle. Adjust the position so that it does not rock and will not put a strain on the plastic handle when the through bolts are tightened. Refer to the picture on page 6. Hold in this position using a "C" clamp on one of the ears. Drill a 1/4 inch hole through the bracket and handle on the exposed ear.
4. Install a 1/4 inch bolt with a plain washer under the head and a lockwasher under the nut. Tighten the nut, remove the clamp and drill the 2nd hole. Install the 2nd bolt and tighten the nut.
5. Attach the shift cable and cable anchor bracket to the jet drive, using 2 - 1/4-20 x 5/8 bolts and flat washers. Move the bracket forward and tighten the bolts. Using a light finger pressure on the gate, move the gate toward reverse until the cam roller is nested in the neutral notch of the cam.

Adjust the shift cable ends such that the roller is in the neutral notch when the shift handle is in neutral. Tighten hardware.

Shift to forward. The roller should be at the end of the slot in the cam such that the gate cannot be forcibly rotated toward reverse. Pull on the gate by hand to verify this.

If this forward lock condition is not met, readjust the cable positions, giving less importance to the roller position in neutral.

6. Return to page 2, paragraph 13 and proceed with setting motor height.

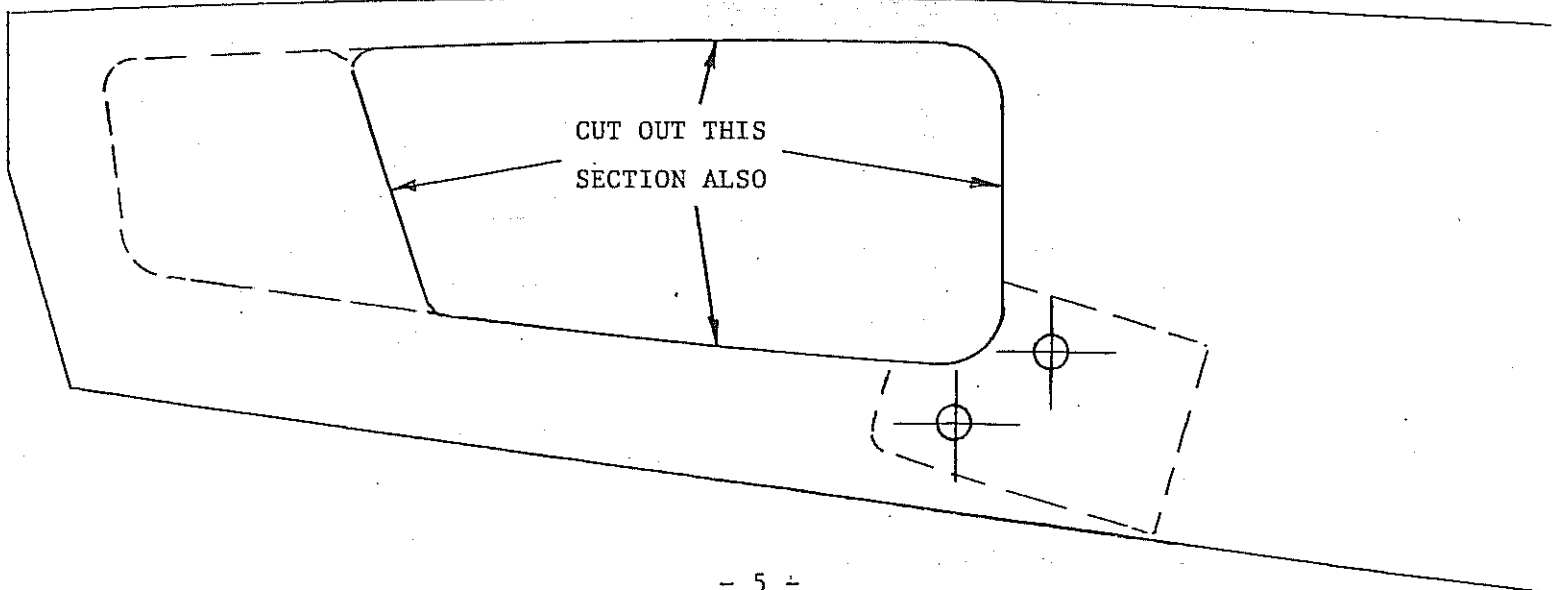



MODEL "Z30SM" 30 HP

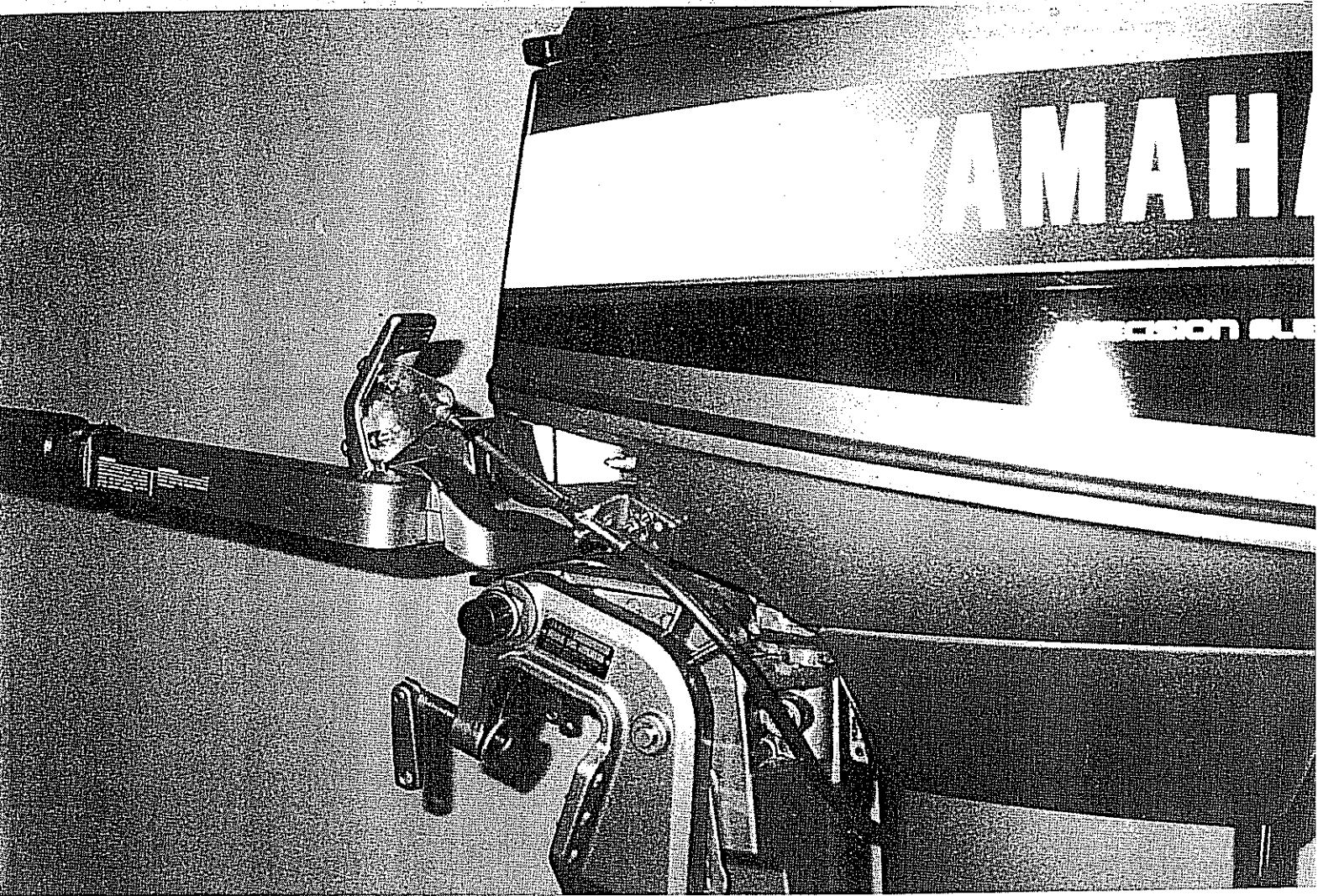

# MAINTENANCE AND LUBRICATION OUTBOARD JET DRIVE

## BEARING LUBRICATION

A grease gun and tube of grease is supplied with your jet drive. We recommend greasing the bearing every 10 hours. Make greasing a part of your cleanup after the days use. Pump in just enough grease to fill the lube hose. Then reconnect the lube hose coupling to the zerk grease fitting.

Every 30-40 hours, pump in extra grease so as to purge any moisture. The texture of the grease coming out gives an indication of conditions inside the bearing housing. A gradual increase in moisture content indicates seal wear. If the grease begins to turn dark, dirty gray, the bearing and seals should be inspected and replaced if necessary. Some discoloration of the grease is normal during the break in period on new sets of seals.

We have selected a water resistant grease of the proper consistency for this application. If you use a substitute grease, be sure it is water resistant and of the same consistency.

## IMPELLER

Your jet drive is equipped with a key to protect the unit in the event of a rock jam. This can be reached by removing the water intake, and then the driveshaft nut, similar to a propeller drive. After replacing the key, pull the shaft nut up tight to remove any play between the impeller and shaft. Note the position of the impeller shim washers, and replace them in the same order.

## REVERSE GATE MECHANISM

Occasionally check adjustment of the gate shifting linkage. In "forward" the gate should be firmly locked in position. Pull on the gate by hand to verify this. This will prevent wave action from accidentally shifting the gate into reverse as the boat is violently maneuvered

## GENERAL

Check all mounting bolts, intake screws, linkage connections, etc., occasionally to be sure they are tight.

## SALT WATER USE

Aluminum and stainless steel have been used in the construction of your jet drive. These materials have either been treated or are inherently resistant to corrosion. It is recommended, however, that when not in use the motor be tipped up so that the jet unit is out of the water. When used in salt water more than in fresh water, remove mounting hardware, grease, and reassemble once a year. Failure to do this may result in hardware that is difficult if not impossible to remove at a later date.

## GUARANTEE

Due to inflexible government regulation, we do not have a written warranty. We have, however, a good reputation for fairness with our customers which we intend to maintain. If you think you have a warranty situation, regarding material, workmanship, call us before making repairs.

Specialty Manufacturing Company  
Outboard Jets  
2035 Edison Avenue  
San Leandro, CA 94577

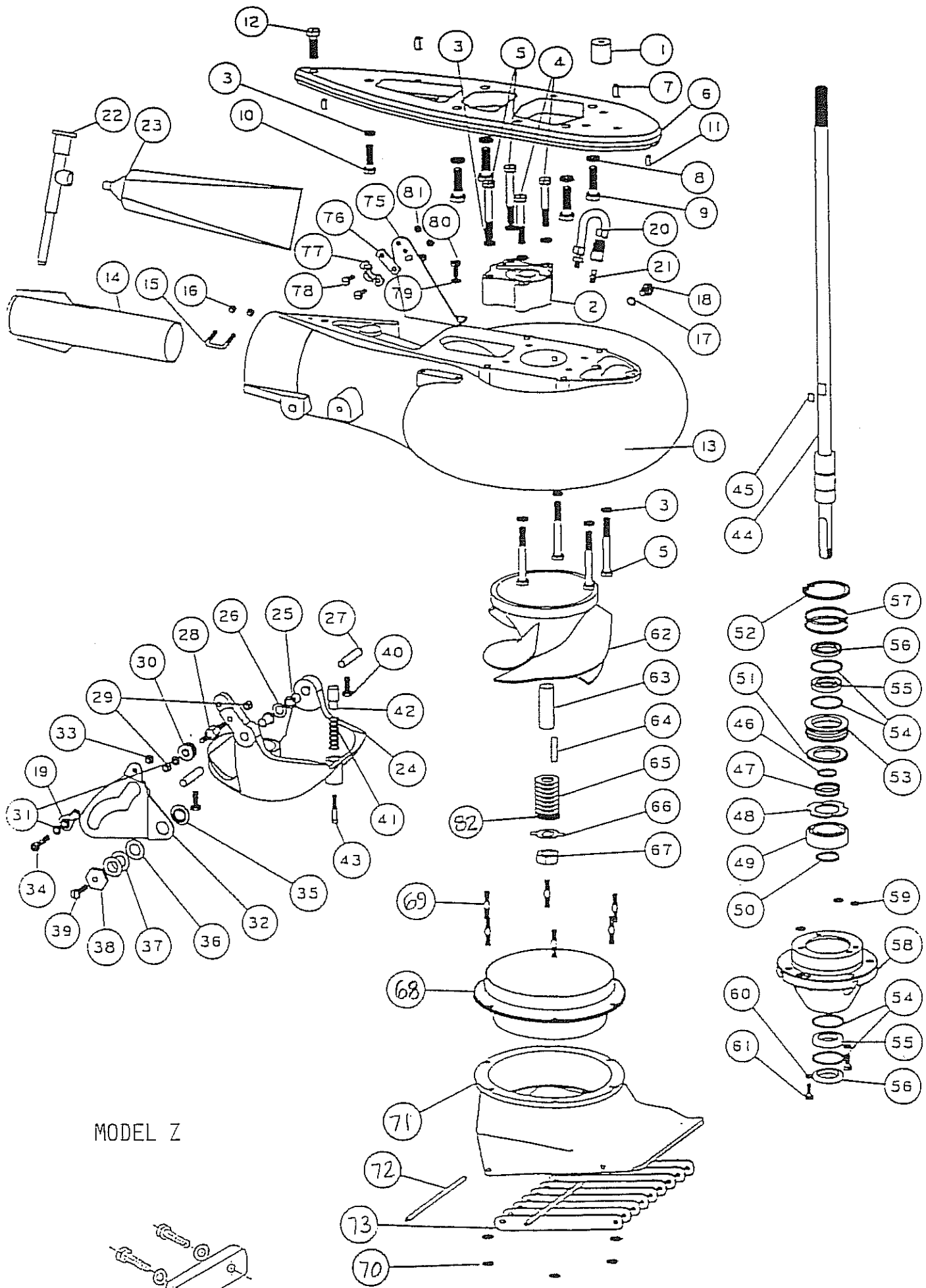

MODEL Z

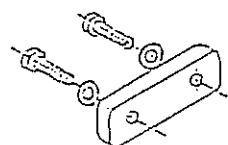

ANODE KIT 1693

# MODEL Z YAMAHA

REF	QTY	PART NO.	DESCRIPTION	REF	QTY	PART NO.	DESCRIPTION
1	1	928	SPONGE COLLAR Z SHIFT GUIDE	46	1	41	SHAFT BEARING THRUST RING
2	1	906	PUMP ADAPTER Z	47	1	477	COLLAR BACKFIT 7205
3	9	640	WASHER SPRING LOCK 5/16	48	1	832	THRUST WASHER
4	2	598	BOLT HEX HD 5/16-18 X 2 1/4	49	1	504	BEARING 7205B-UA
5	6	599	BOLT HEX HD 5/16-18 X 2 3/4	50	1	511	TRUARC 5100-98
6	1	904	ADAPTER PLATE Z	51	1	833	SPACER
7	2	616	DOWEL PIN 6 X 16 MM	52	1	512	TRUARC N5002-212ZD
8	4	636	WASHER SPRING LOCK M10	53	1	433	UPPER SEAL CARRIER W/SEALS & O RINGS
9	4	592	BOLT HEX HD M10-1.25 X 35MM	54	4	517	SPIROLOX RR-150S
10	1	591	BOLT HEX HD M8-1.25 X 30MM	55	2	506	SEAL INNER
11	2	631	DOWEL PIN 3/16 X 1/2	56	2	507	SEAL OUTER 6324-S
12	1	606	BOLT HEX HD 3/8-16 X 1 1/4	57	2	526	O RING 568-135 3/32X1 15/16X2 1/8
		90200	VOLUTE WITH GATE Z	58	1	917	BEARING CARRIER W/SEALS & O RINGS Z
13	1	902	VOLUTE WITH EXHAUST TUBE Z	59	3	521	O RING 568-011 1/16X5/16X7/16
14	1	80	EXHAUST TUBE ASSY MED 2	60	2	637	WASHER SPRING LOCK #10
15	1	846	CLIP EXHAUST TUBE 1	61	2	561	FIL HD SLOTTED 10-24 X 5/8
16	2	621	NYLOC 10-32	62	1	8.21	IMPELLER 5 7/8 W/36.1 SLEEVE
17	1	1023	WASHER FIBER 3/8	62	1	8.23	IMPELLER 6 1/8 W/36.1 SLEEVE
18	1	1022	BOLT HEX HD 3/8-16 X 1/2	62	1	1737	IMPELLER 6 1/8 W/36.1 SLEEVE, STAINLESS
19	1	553.2	BALL END 1/4X10-32 CABLE	63	1	36.1	SHAFT SLEEVE PLASTIC MEDIUM
20	1	976	LUBE HOSE ASSY	64	1	782	IMPELLER TEE KEY - SQUARE
21	1	539	ZIRC FITTING 1/4-28	64	1	1705	IMPELLER TEE KEY - 1/2 ROUND
22	1	550	GREASE GUN	65	8	21	SHIM WASHER MEDIUM
23	1	552	GREASE 10 OZ TUBE 630-AA	66	1	805	NUTKEEPER MED/PKG 2 PER BAG
24	1	1175	REVERSE GATE MEDIUM	67	1	22.1	SHAFT NUT 5/8-18 BRASS
25	2	535	NYLINER 3/8 1D X 1D X 11/16			1448	INTAKE ASSY 5 7/8 FLANGED W/ GRILL & LINER
26	1	1177	SPRING GATE PIVOT 3/8	68	1	1678	LINER 5 7/8 FLANGED
27	2	822	PIN GATE PIVOT 3/8 MEDIUM	69		1447	INTAKE ASSY 6 1/8 FLANGED W/ GRILL & LINER
28	1	1043	SHAFT ROLLER	68	1	1521	LINER 6 1/8 FLANGED
29	2	624	NYLOC 1/4-28	69	6	1300	STUD - INTAKE MEDIUM
30	1	1042	ROLLER ASSY	70	6	623	NYLOC 1/4-20
31	1	635	1/4 WASHER AN960C416	71	1	1326	INTAKE PAINTED ONLY MED FLANGED
32	1	1035	SHIFT CAM MEDIUM	72	2	14	GRILL ROD
33	1	623	NYLOC 1/4-20	73	9	16	GRILL BAR MEDIUM
34	1	573	BOLT HEX HD 1/4-20 X 3/4			171	BRACKET ASSY MORSE W/CLAMP & HARDWARE
35	1	1037	BUSHING CAM	75	1	166	BRACKET CABLE SUPPORT
36	1	1038	WASHER CAM	76	1	542	SHIM MORSE A035777
37	2	1039	SHIM-CAM	77	4	543	CLAMP CHRYS 154317
38	1	1036	CAM ECCENTRIC DRILLED	78	2	561	FL JD SLOTTED 10-24 X 5/8
39	1	574.1	BOLT HEX HD 1/4-20 X 1 PATCH	79	2	635	1/4 WASHER AN960C416
40	2	574	BOLT HEX HD 1/4-20 X 3/4 PATCH	80	2	572	BOLT HEX HD 1/4-20 X 5/8
41	1	1170	SPRING GATE BUMPER	81	2	619	NYLOC 10-24
42	1	1169	GATE BUMPER	82	1	1718	TORSIONAL DAMPER 5/8
43	1	559.2	FIL HD SLOT 10-32X 1 1/4 PATCH				
44	1	1255	SHAFT ONLY, Z30S, 14T, 24-1/4 LG.				
		1256	SHAFT ASSY COMPLETE, Z30S, 14T W/1275 KEY				
44	1	1322	SHAFT ONLY, Z30L, 14T 29 LG.				
		1323	SHAFT ASSY COMPLETE, Z30L, 14T W/1275 KEY				
44	1	910	SHAFT ONLY, ZS, 14T 24 5/8 LG.				
		911	SHAFT ASSY COMPLETE, ZS, 14T, W/1275 KEY				
44	1	914	SHAFT ONLY, ZL 14T, 29 7/16 LG.				
		915	SHAFT ASSY COMPLETE, ZL, 14T, W/1275 KEY				
45	1	1275	KEY, TEE WATER PUMP				
				NOTE: FLUSH SCREW AND WASTER METRIC ON BLUE VOLUTES			
				17	1	1025	WASHER FIBER M8
				18	1	1024	BOLT HEX HD M8-1.25 X 12

**TILLER STEERING:**

SIZE	TORQUE
1/4-20 (M6)	8-9 FT-LBS
5/16-18 (M8)	12 FT-LBS
3/8-16 (M10)	22 FT-LBS

SHIFT ROD ASSY 1215, 1217, SEE PAGE 24

SHIFT CABLE ASSY 1261, 1262, SEE PAGE 27, Pg. 16  
1317, SEE PAGE 28

BEARING, SEAL, SNAP & "O" RING KIT 803.1

SHIFT ROD ASSEMBLY  
 YAMAHA MODEL Z40M  
 TILLER STEERING - CAM-GATE  
 1215 SHORT  
 1217 LONG

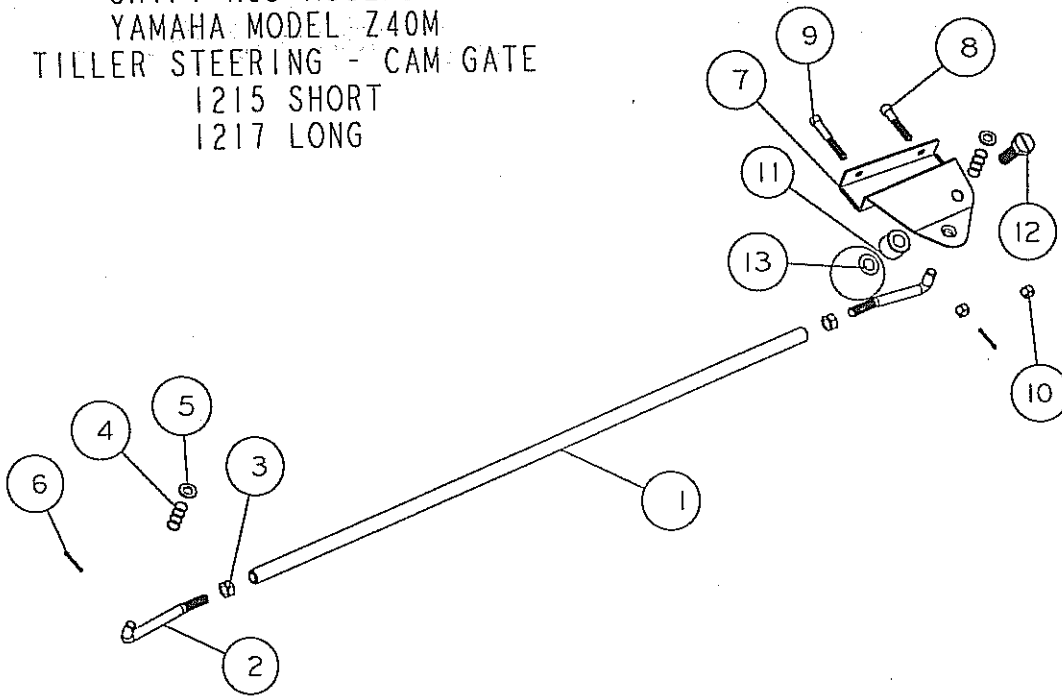

REF	QTY	PART NO	DESCRIPTION
1	1	1213	SHIFT ROD ZSM 18 7/8 SHORT
1	1	492	SHIFT ROD U2L,V,ZLM 23 1/8 LONG
2	2	24	ROD END FORMED
3	2	622	NUT HEX 1/4-28
4	2	1164	SPRING-ROD END
5	2	635	1/4 WASHER AN960C416
6	2	645	COTTER PIN 1/16 X 1/2
7	1	1214	SHIFT LEVER ZM
8	1	559	FIL HD SLOTTED 10-32 X 1
9	1	558	FIL HD SLOTTED 10-32 X 1 1/4
10	2	621	NYLOC 10-32
11	1	886	SPACER 5/16ID X 1/2
12	1	602	BOLT HEX HD 5/16-18 X 1
13	1	551	KNOB 1 3/8

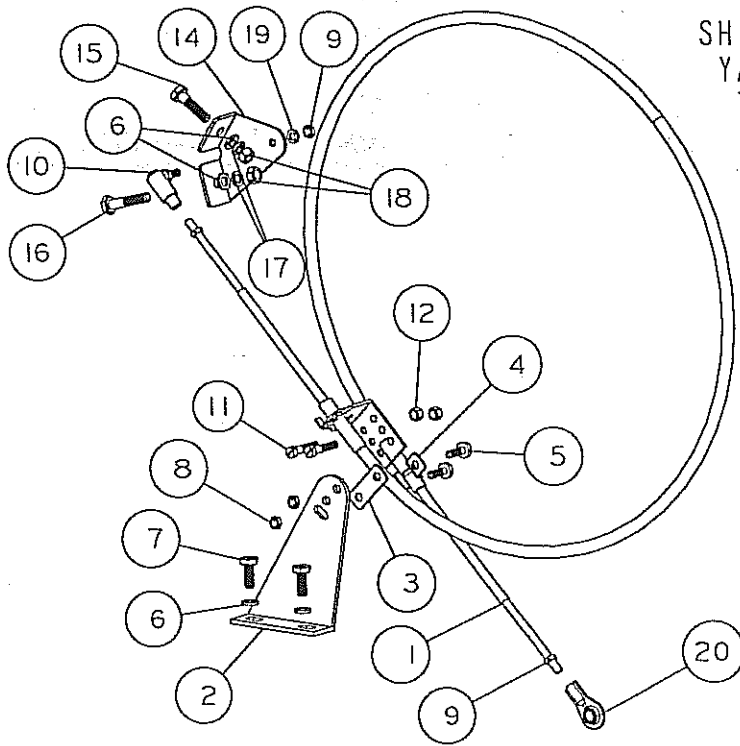

SHIFT CABLE ASSEMBLY  
 YAMAHA MODEL Z30M  
 TILLER STEERING  
 1261 SHORT  
 1262 LONG

REF	QTY	PART NO	DESCRIPTION
1	1	555	CABLE 3 FT MOR 33C SUPREME SHORT
1	1	549	CABLE 3 1/2 FT MOR 33C SUPREME LONG
2	1	156	BRACKET CABLE SUPPORT
3	1	542	SHIM MORSE A035777
4	1	543	CLAMP CHRYS 154317
5	2	561	FIL HD SLOTTED 10-24 X 5/8
6	4	635	1/4 WASHER AN960C416
7	2	572	BOLT HEX HD 1/4-20 X 5/8
8	2	619	NYLOC 10-24
9	3	621.1	HEX NUT 10-32 JAM
10	1	543.1	CABLE ANCHOR MORSE 36174
11	2	559.1	FIL HD SLOTTED 10-32 X 1
12	2	621	NYLOC 10-32
13	1	544.1	BALL JOINT MORSE 31799-001
14	1	1252	SHIFT LEVER Z30
15	1	576.1	BOLT HEX HD 1/4-20 X 1
16	1	585	BOLT HEX HD 1/4-20 X 1 1/4
17	2	638	WASHER SPRING LOCK 1/4
18	2	628	NUT HEX 1/4-20
19	1	637	WASHER SPRING LOCK No. 10
20	1	553.2	BALL END 1/4X10-32 CABLE

SCALE

6. AUG. 97

SHIFT CABLE ASSEMBLY  
YAMAHA MODEL Z50, Y70  
TILLER STEERING  
1317

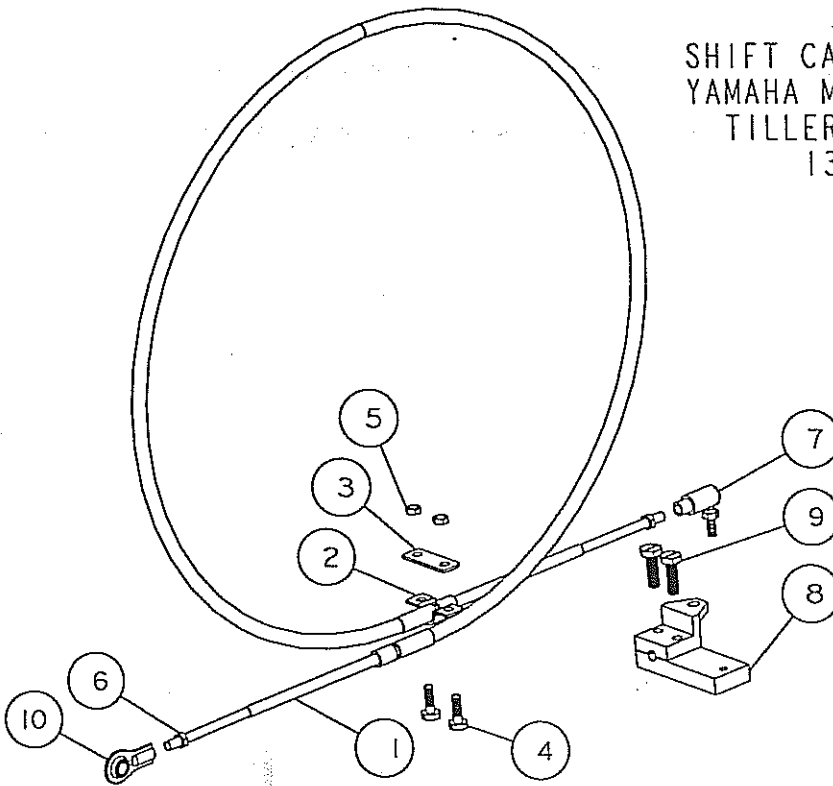

REF	QTY	PART NO	DESCRIPTION
1	1	549	CABLE 3 1/2 FT MOR 33C SUPREME
2	1	543	CLAMP CHRYS 154317
3	1	542	SHIM MORSE A035777
4	2	561	FIL HD SLOTTED 10-24 X 5/8
5	2	619	NYLOC 10-24
6	2	621.1	HEX NUT 10-32 JAM
7	1	544.1	BALL JOINT MORSE 31799-001
8	1	1316	CABLE BLOCK Z Y TILLER
9	2	573	BOLT HEX HD 1/4-20 X 3/4
10	1	553.2	BALL END 1/4X10-32 CABLE

6.AUG.97