

MEDIUM SERIES

PIN 822 (2)
 NYLINER 535 (2)
 BOLT 574 (2)

PIN 12 (2)
 RUBBER SLV 37 (2)
 NYLINER 534 (2)
 ROLL PIN 618 (2)

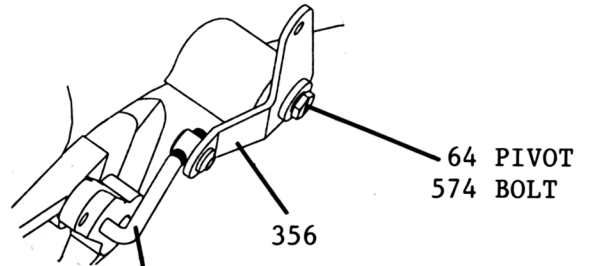

24 ROD END
 635 WASHER
 645 COT PIN
 533 NYLINER

BELLCRANK
 BEFORE CAM GATE

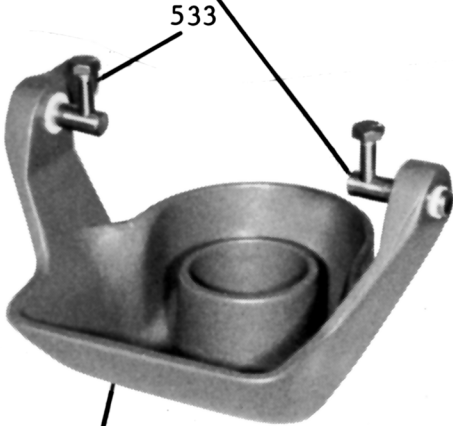

REVERSE GATE
 Pivot bushings in gate
 See Table Below

BEFORE CAM GATE

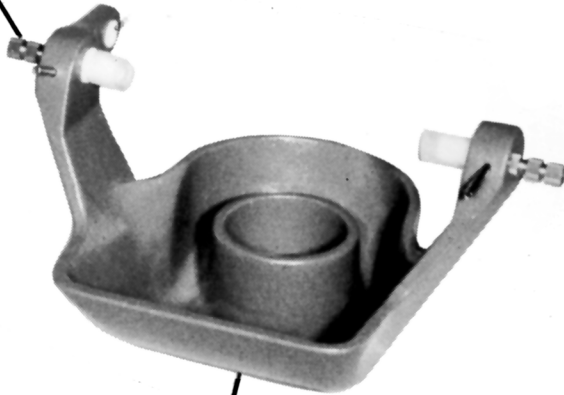

REVERSE GATE
 Pivot bushings in main hsg
 See Table Below

MODEL	GATE ONLY	GATE ASSY
-------	-----------	-----------

A		835 For Shift Rod
B		
A74		
Q		
U2,3		
U4M		

C		836 For Cable
EF		
J		
* QR		
U4R		
Z		
AB		
AF		

MODEL	GATE ONLY	GATE ASSY
-------	-----------	-----------

A	45	47
B		
A74		
Q		
U2,3		
U4M		

C	85	91
EF		
J		
QR		
U4R		

MODELS A, B, A74, C, E, F, J, Q, U, Z
 AB, AF

* No shift handle on motor

